

7

Air Brakes



What You'll Learn

After reading this chapter you will be able to:

- identify the components of an air brake system
- explain how an S-cam foundation brake works
- describe what happens when one or more air brake system components fail
- explain how trailer brakes are applied

Why Air Brakes?

Air brakes are used on heavy vehicles for a number of reasons:

- Air brake systems use a much greater force to apply the brakes than hydraulic braking systems do. This greater force is needed to cope with the heavy loads of commercial vehicles.
- Air brake systems are more tolerant to small leaks. The smallest leak in a hydraulic system could result in brake failure. An air brake system includes a compressor to generate more compressed air as needed.
- Air brakes are used on heavy vehicles because they have proven they are capable of stopping these vehicles safely.

Basic Air Brake Components

The basic components of a simple air brake system showing the brakes applied.

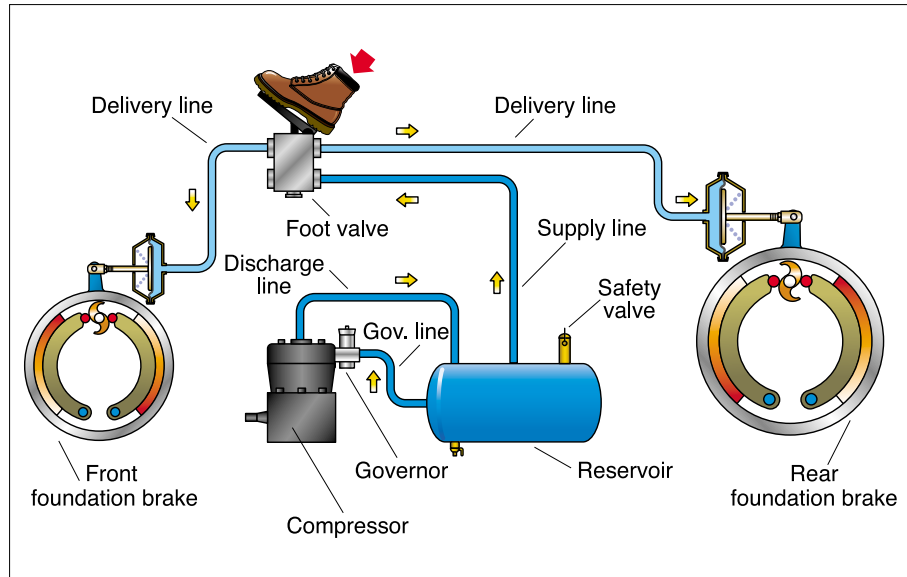

This diagram shows the components that are used to make the simplest possible air brake system:

- A **compressor** to pump air, with a **governor** to control the compressor.
- **Air lines** to allow the pressurized air to flow between the air brake system components.
- A **reservoir** to store the compressed air.
- A **brake pedal** (usually called a **foot valve**) to apply the brakes by directing compressed air from the reservoir to the brakes.
- **Foundation brakes**, including brake chambers, slack adjusters, brake linings and drums or rotors, to transfer the force generated by the compressed air through a mechanical linkage to apply the brakes.

Air Brake Chamber Components

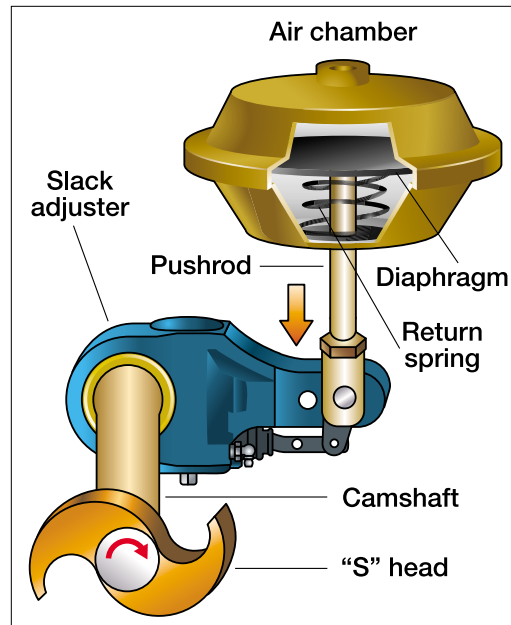

Diagram of a typical clamp-type air brake chamber

The above diagram shows the most common device used to apply truck air brakes – the **air brake chamber**. It converts the force of compressed air into a strong mechanical force through the pushrod and slack adjuster.

The air brake chamber consists of a flexible diaphragm clamped between two steel housings. The diaphragm construction is similar to a tire sidewall, consisting of a reinforced fabric core with a rubber coating. Other main parts are the pushrod and plate assembly, and a return spring.

Long stroke and regular stroke brake chambers

Many new air brake systems are equipped with long stroke brake chambers. As the name implies, a long stroke chamber design has a longer pushrod stroke than the pushrod of a standard brake chamber.

Long stroke brake chambers can usually be identified by square-shaped inlet ports or a nametag on a clamp bolt.

Air brake chamber — air pressure applied

Compressed air generates force causing the pushrod to extend out of the brake chamber.

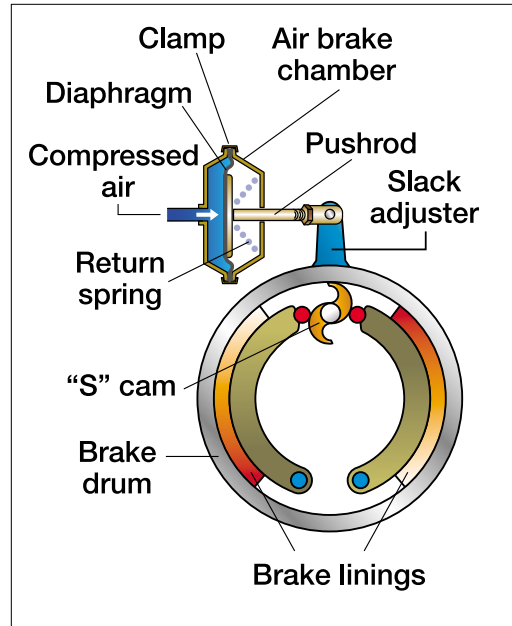

This diagram shows how air under pressure is admitted to one side of the diaphragm, causing it to inflate. As it inflates, the diaphragm pushes against the pushrod, plate assembly and the return spring, causing them to move. Note the position of the slack adjuster – it is now at about a 90 degree angle to the pushrod.

The amount of pushrod force is governed by the air pressure (in pounds per square inch) and the effective surface area of the diaphragm (in square inches). The pushrod force is exerted against the brake mechanism, causing the brakes to apply.

The most common size air chamber used on truck drive axles and trailer axles is a regular Type 30 clamp type chamber with 30 square inches of effective diaphragm area.

Air chambers are very powerful. The common Type 30 regular chamber shown in the diagram above if applied with air pressure of 100 p.s.i. (690kPa) develops a pushrod force of 3,000 pounds.

Air chambers are made in a number of sizes, ranging from Type 9 (with nine square inches of effective diaphragm area) to Type 36 (with 36 square inches of effective diaphragm area). The range of sizes allows the truck engineer to match air chamber force with axle capacity so that no axle is under or over braked.

However, even though truck air brake system pressures are 100 p.s.i. (690 kPa) and above, much lower air application pressure, usually less than 20 p.s.i. (138 kPa) is used to make normal stops.

Definition

Foundation Brake refers to the mechanical parts of the brake system inside the wheel.

Foundation brakes: s-cam type

The brake assembly at each wheel is generally called the **foundation brake**. The assembly consists of the brake parts around the wheel that are operated by the air brake system, including the brake chamber. The most popular type of foundation brake is the “S” cam drum brake.

When air pressure is applied to the brake chamber diaphragm, it causes the pushrod to move against the slack adjuster arm which rotates the S-cam to apply the brakes.

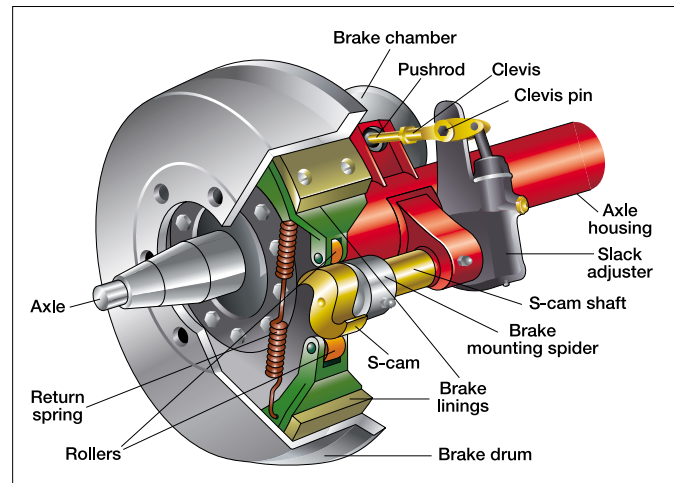

This diagram shows the main components used in the S-cam drum foundation brake. The air brake chamber pushrod is connected to a lever arm called a **slack adjuster**. The slack adjuster is attached to a camshaft with an S-shaped head called an **S-cam**. Air pressure applied to the chamber causes the pushrod to move forward, causing the slack adjuster to rotate the S-cam. This causes the **brake linings** to press against the **brake drum**, causing friction, which causes the wheel to decelerate, stopping the vehicle.

The slack adjuster is also the means of adjusting the brakes to compensate for brake lining and brake drum wear. Brake adjustment is important and is covered in **Chapter 8 – Air Brake Adjustment**.

Brake shoe **return springs** are used to keep the brake linings away from the drum when the air pressure is released from the air chamber.

The picture on the left shows the brake shoes mounted on the axle housing. The brake drum on the right is mounted on the wheel and rotates with it.

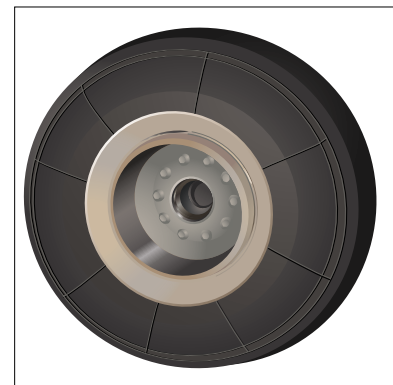
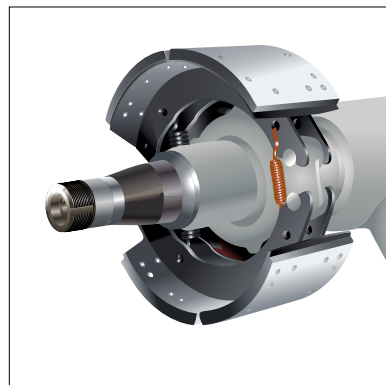

Compressor

The first requirement of an air brake system is a means of compressing air and storing it in reservoirs (tanks) so that it is available for instant use.

The source of the compressed air is the **compressor**, which takes in air from the atmosphere and compresses (pressurizes) it. The compressed air is then pumped through an air line to a supply reservoir.

A gear-driven compressor and governor

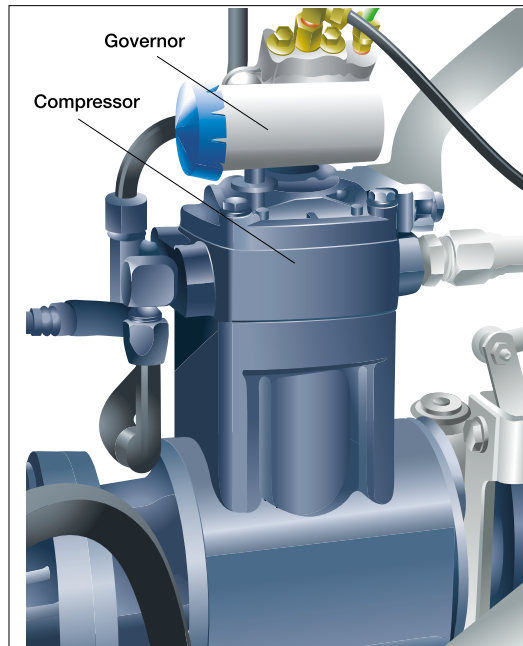

RoadSense Tip

Check belt tension by pressing down on the belt midway between the pulleys. If you can press it in more than double the width of the belt, the tension needs to be adjusted.

The compressor is mounted on the engine of the bus or truck. On most new engines, the compressor is mounted on the side of the engine and driven by gears. A belt, like a fan belt, drives some compressors. As long as the engine is running, the compressor will be running.

All trucks use piston-type air compressors. They may have one, two or four cylinders depending on the volume demands of the particular vehicle.

When air is compressed, its temperature rises. With a truck air compressor operating at a pressure of 120 p.s.i. (827 kPa), the air temperature as it leaves the compressor is over 204° C(400° F).

To prevent the compressor from overheating, two types of cooling systems are used. The most common method on heavy trucks is to circulate engine coolant through the compressor, while some compressors on lighter units may be air-cooled.

Oil is used for lubricating the moving parts of the compressor, just like oil is used to lubricate the moving parts of a car's engine. Oil also helps to cool the compressor. The compressor is usually lubricated from the same oil as the engine of the truck or bus, though some compressors have their own separate oil supply. It is important to check that there is sufficient oil supply.

Since the compressor pumps air, it needs a supply of clean air to work properly. Air from the atmosphere supplies both the truck engine and the compressor. An air filter is used to keep this supply clean. The air filter should be checked regularly to make sure it is not clogged, as this would restrict air flow.

A piston-type compressor operates on a similar principle to that of the intake and compression strokes of a typical car engine.

Diagram of an air compressor.

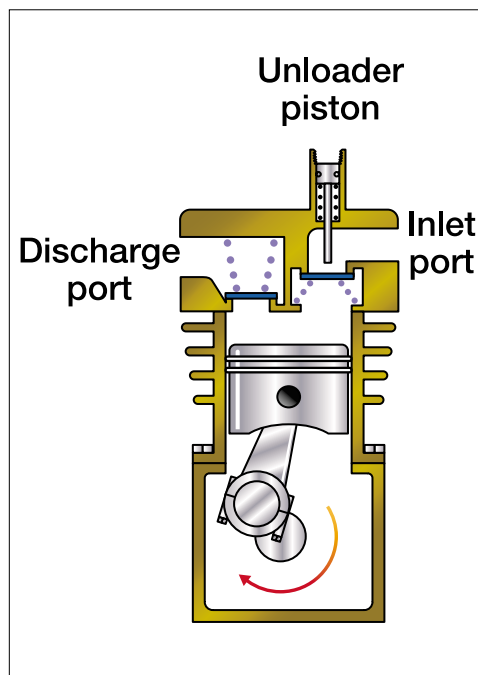

Intake stroke

As the piston moves down in the cylinder, it creates a lower pressure (vacuum) within the cylinder than the atmospheric pressure outside the compressor. With the inlet valve open, air is then drawn into the cylinder to fill the vacuum.

Air enters the compressor cylinder on the intake stroke. On the compression stroke, the inlet valve is closed and the discharge valve is open to feed the compressed air toward the air reservoir.

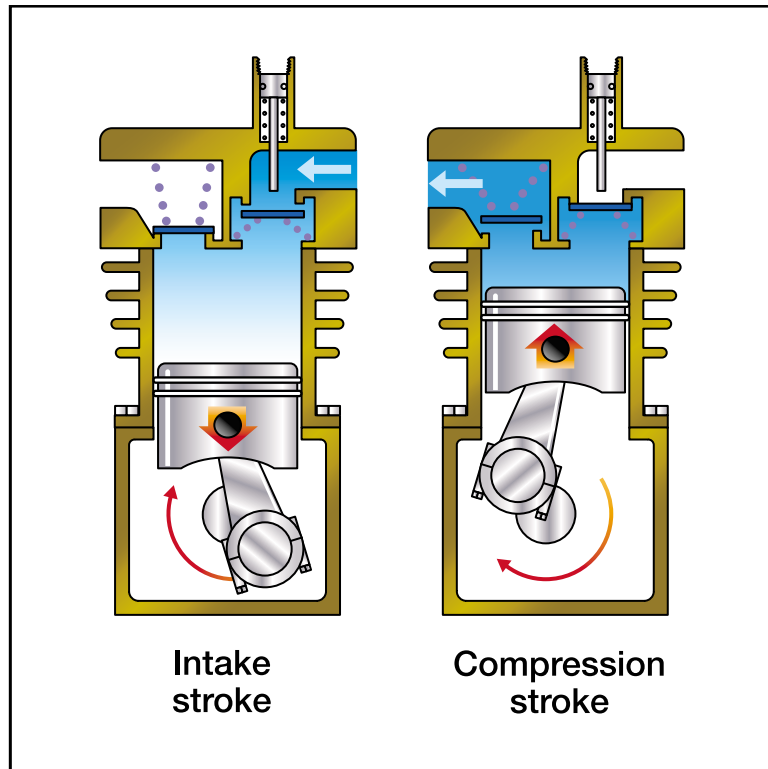

Fast Fact

Many current air brake systems operate with a maximum pressure of approximately 125 p.s.i. (882 kPa).

Compression stroke

When the piston reaches the bottom of the cylinder it then begins to rise. The inlet valve closes, causing the air in the cylinder to compress. As the piston nears the top of the stroke, the discharge valve opens, and the pressurized air is forced past the valve and into the discharge line leading to the reservoir.

Fast Fact

Vehicle safety standards require that the governor must be set to restart the compressor if the air pressure drops below 85 p.s.i. (586 kPa).

Governor

The compressor is capable of compressing air to over 500 p.s.i. (3448 kPa). This is far higher than is needed to operate an air brake system. Most current air brake systems operate with a maximum pressure of 125 p.s.i. (862 kPa).

There needs to be a way to stop compressing air once a certain air pressure has been reached. And, if the air pressure in the tanks drops below a certain level (such as after a series of brake applications), there needs to be a way to start compressing air again.

This is the job of the **governor**. When sufficient pressure has been built up, the governor causes the compressor to go into an “unloading” stage.

Fast Fact

The compressor must be capable of building pressure in the reservoirs from 50 p.s.i. to 90 p.s.i. within three minutes at a fast idle (1000 – 1200 r.p.m.).

The governor causes the unloader piston in the compressor to open the inlet valve.

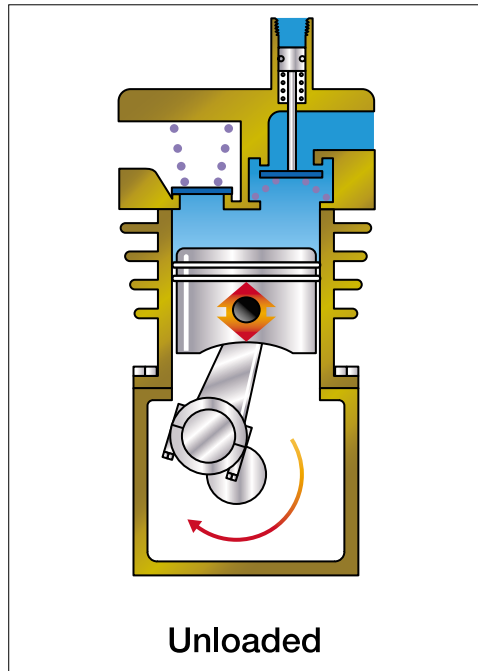

Governors are usually set to unload the compressor (stop the compressor from pumping air) when the air pressure reaches about 125 p.s.i. Although the maximum pressure on different vehicles may vary between 105 and 135 p.s.i. (724 and 931 kPa), the range between minimum and maximum pressure should be approximately 20 p.s.i. (138 kPa).

For example, if the maximum air pressure was 125 p.s.i., the governor would restart the compressor if air pressure in the reservoirs dropped to 105 p.s.i. (applying the brakes two or three times would likely cause the air pressure to drop to this level). At any rate, the governor must restart the compressor if the air pressure drops below 80-85 p.s.i. (552-586 kPa).

Reservoirs

Steel tanks (known as **reservoirs**) are used to store the compressed air from the compressor.

Fast Fact

The safety valve is sometimes called a pop-off valve.

Air reservoir, showing safety valve on top and drain cock on the bottom.

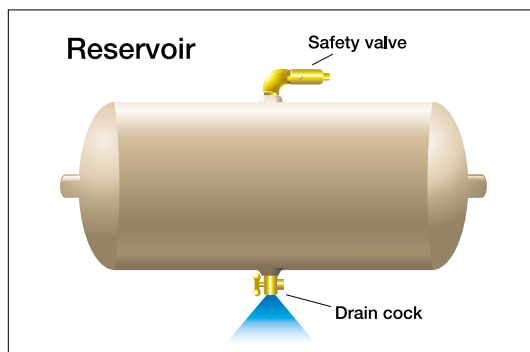



RoadSense Tip

When draining reservoirs don't just briefly open and close the drain cocks. Allow plenty of time for the air to completely drain.



Warning

Compressed air can be dangerous if it escapes, particularly to eyes and to ears.

Avoid being in the direct path of compressed air, such as when draining the reservoirs.

A **safety valve** will be installed on the first reservoir to protect the reservoirs from being over-pressurized and bursting if the governor was to fail to unload the compressor. The safety valve consists of a spring-loaded ball to allow reservoir air to exhaust into the atmosphere. The valve's pressure setting is determined by the force of the spring. Safety valves are normally set to vent the excess pressure at approximately 150 p.s.i. (1034 kPa).

If the safety valve has to relieve the pressure, this means that the governor or compressor needs service or repair. Only a qualified mechanic should do this.

The air that is delivered from the compressor usually contains some water vapour that condenses into liquid water. This is why the supply reservoir is often called the **wet tank**. Most compressors also pass a small amount of oil and carbon particles. The oil and any other contaminants mix with the water, making a grey sludge.

If allowed to accumulate, this sludge would enter other components of the braking system. An excess of water in the system causes trouble with valves and other parts. In winter, water in the system may freeze, causing malfunction of valves or brake chambers.

To prevent this sludge from contaminating the air valves in the system, **drain valves** (also known as **drain cocks**) are installed in all reservoirs. Draining the reservoirs can prevent this sludge build up. Most manufacturers recommend that reservoirs be drained daily.

Foot Valve

Pressing on the brake pedal (called the foot valve treadle) applies the air brakes, just like stepping on the brake pedal applies the brakes in a car.

A foot brake valve.

Fast Fact

The maximum brake application will not exceed the pressure in the reservoirs.

For example, if reservoir pressure is 40 p.s.i. (276 kPa), the maximum brake application you could make would not exceed 40 p.s.i.

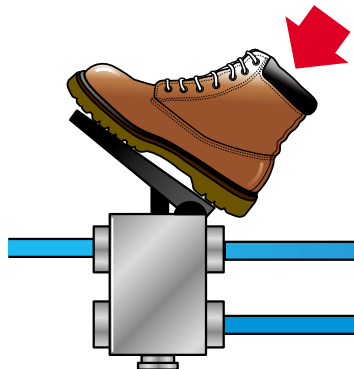

The treadle (pedal) of a foot valve has a springy feel that is quite different from the feel of a hydraulic brake pedal of a car. For one thing, you really don't have to press harder on a foot valve to apply more braking force – you simply have to press it down a bit farther. As long as the foot valve is held in one position, the air pressure delivered to the brake system will remain constant.

Releasing the foot valve allows the application air to be exhausted through the assembly's exhaust ports to the atmosphere.

In effect, it is a foot-controlled pressure regulator. It is the device that allows you to select any application pressure needed to make a gentle, or a very rapid stop.

A unique feature of a foot control valve is the ability to maintain the application pressure that you have chosen, even if there are small leaks downstream from the foot valve. You need only to maintain the treadle position and the foot valve will momentarily open, replenish any air that has been lost, and then close – all automatically.

How Air Brakes Work

Brakes applied

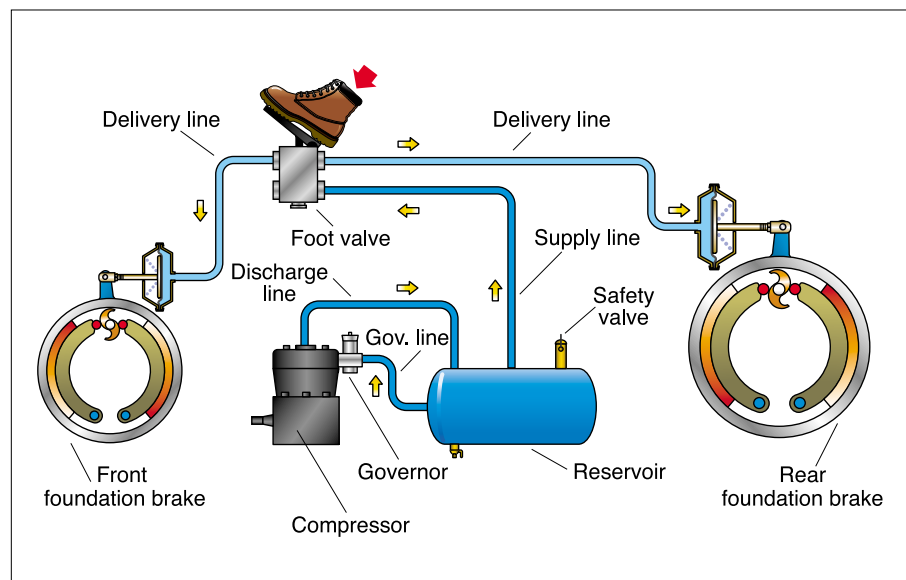

The driver has depressed the foot valve to apply the brakes.

In this diagram, air at full system pressure is indicated by the coarse shading in the line connecting the supply reservoir to the foot valve.

The driver is making a brake application. This can be seen by the light shading in the air lines connecting the foot valve to the air chambers. Arrows show the direction of air flow.

The air chambers are pressurized and the brake linings have contacted the brake drums, slowing the vehicle.

Brakes released

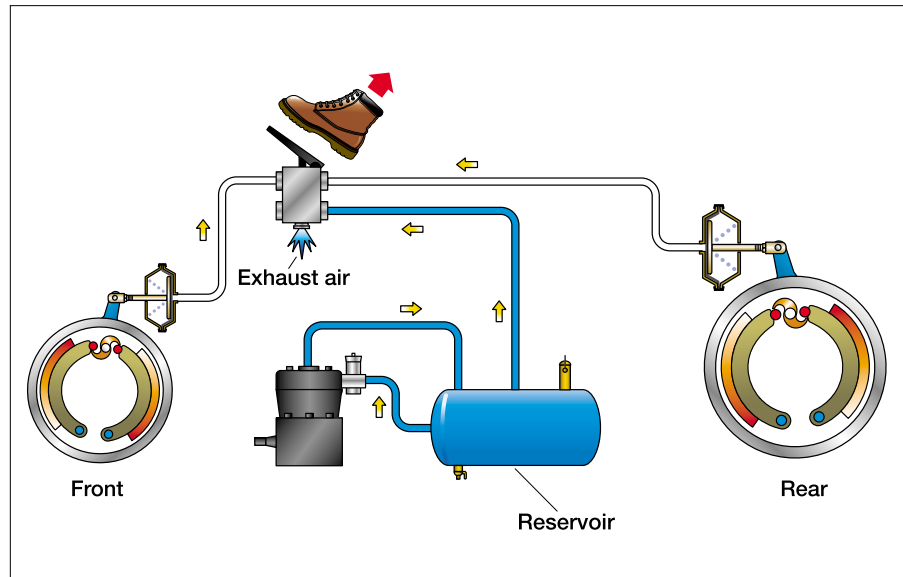

When the driver releases the foot valve, air pressure in the brake chambers exhausts into the atmosphere.

In this diagram, the driver's foot is off the brake pedal, allowing the brakes to release. This action has caused an exhaust port in the bottom of the foot valve to open, allowing the air that was applied to the brake chambers to escape. Note the burst of exhaust air below the foot valve.

The return springs in the air chambers have returned the pushrod assembly to the released position, and the slack adjusters and S-cams have rotated to their released position.

Brake shoe return springs (not shown) have retracted the brake linings away from the brake drums.

Dual Air Brake Systems

Dual air brake systems have been in use since the mid-1970s.

A dual air brake system with the brakes applied

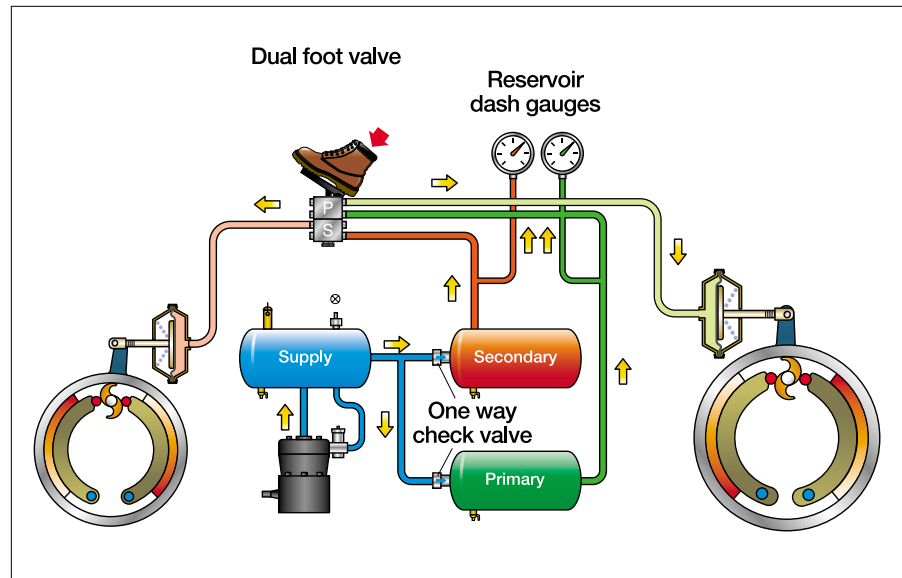

The device that made dual systems possible is the **dual foot valve**. It is actually two control valves operated by a single pedal. This allows the brake system to be divided into two completely independent sections. Each section has its own supply, delivery and exhaust ports.

Fast Fact

Cars have had dual braking systems since 1968 to reduce the chance of a total brake failure.

The two sections of the dual foot valve are named **primary** and **secondary**. The primary section is located closest to the pedal, and in many systems operates the drive axle brakes. The secondary section usually operates the steering axle brakes.

When the driver applies the brakes, both sections of the dual foot valve are activated. Air from the primary tank is applied to the rear axle brakes and air from the secondary tank is applied to the front axle brakes.

Most dual systems use three reservoirs, a supply reservoir as before, and two service reservoirs, one for each section of the dual system. Each service reservoir is filled through a one-way check valve, and there are two reservoir pressure gauges, one for each service reservoir.

Even in the event of a total failure in one or the other system, the driver is able to make a controlled stop, using only the foot valve, although maximum braking power will be reduced.

There are other ways of splitting a dual air brake system, but however it is divided, if one of the systems fail, the driver is still able to make a controlled stop.

Note the change in terminology for the reservoirs. The first reservoir (wet tank) is called the **supply reservoir**. The two service reservoirs are

called the **primary reservoir** and **secondary reservoir**, indicating the section of the dual foot valve that they supply.

Some dual systems have the low air warning device connected to the supply reservoir as shown, while others have two separate connections, one located on each service reservoir.

Components of a Dual Air Brake System

Supply, primary and secondary reservoirs

The compressed air from the compressor contains several contaminants including water vapour, oil mist and carbon particles. Most contaminants settle in the supply reservoir. Primary and secondary reservoirs have been added so that all the air brake components, with the exception of the governor valve, are supplied with cleaner air.

One-way check valve

One-way check valves allow air to flow from the supply reservoir to the primary and secondary reservoirs. As the name implies, a one-way check valve allows air to flow in one direction only. This is so that in the event of a failure in the air compressor, compressor discharge line, or supply reservoir, the air supply in the primary and secondary reservoirs would not flow backward and be lost.

Reservoir pressure gauges

All air brake-equipped vehicles have at least one **air pressure gauge** on the instrument panel to indicate the air pressure in the service reservoir system.

Fast Fact

Some reservoirs have more than one compartment (and more than one drain cock).

The air pressure gauge on the left has a single needle. The air pressure gauge on the right has two needles — one indicating pressure in the primary reservoir, the other showing pressure in the secondary reservoir. The gauge on the left shows pressure in p.s.i. The gauge on the right shows both p.s.i. and kPa.

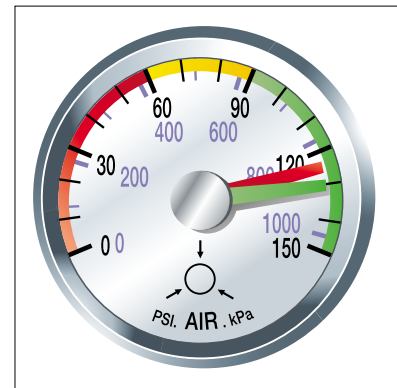
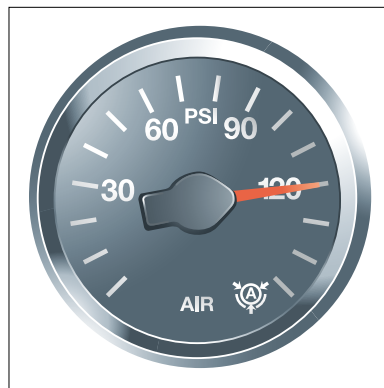

RoadSense Tip

Check gauges frequently to make sure there is adequate air pressure to apply the brakes.

Rather than having two separate reservoir gauges, many vehicles have a single gauge with two needles, indicating the pressure in the primary and secondary reservoirs.

As well, many vehicles have an additional gauge to indicate how much air pressure is being applied when the foot valve is depressed.

The reservoir pressure gauge is mounted in the dashboard so that the status of the air brake system can be monitored while driving and during a pre-trip inspection.

Low air warning device

All vehicles equipped with air brakes must have a visible warning device to indicate if the air pressure in the system drops to a dangerous level. This could occur if there is an air leak, or if you apply the brakes repeatedly and have used up the air supply more rapidly than the compressor can replenish it.

This vehicle has two low-air warning devices — a warning light and a buzzer.



Fast Fact

The low air warning device must activate when air pressure is less than 60 p.s.i. (414 kPa).

The **low air warning device** must come on when air pressure drops below 60 p.s.i. (414 kPa).

A typical low air warning device is a red warning light on the dashboard. There may also be a buzzer.

Some older vehicles are equipped with a low air warning device near the top of the windshield that drops into the driver's view when air pressure drops below approximately 60 p.s.i. This type of warning device is known as a **wig-wag**.

A wig-wag.



RoadSense Tip

If the low air warning comes on, pull over and stop. Do not proceed until you find out why the low air warning came on and until you determine that the air brake system is safe.

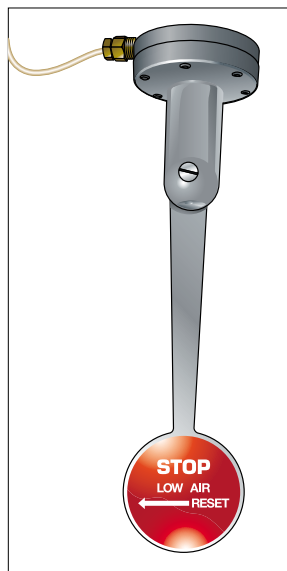

Some wig-wags automatically retract when air pressure rises above the warning level of 60 p.s.i.; some wig-wags need to be manually pushed up to the “out of view” position after the air pressure has risen above the warning level.

When a low air warning device activates, stop the vehicle and find the cause of the air loss. The air pressure remaining in the system (approximately 60 p.s.i.) will be enough to stop the vehicle if you act promptly.

Quick release valve

In the previous diagram, when the driver released the brakes, all the air contained in the air lines and in the air chambers was vented through the foot valve exhaust port. Because of the distance that the exhaust air has to travel, there can be a considerable lag time for the brakes to release.

This is where the **quick release valve** comes in.

A quick release valve allows the brakes to release quickly and fully, by allowing the pressurized air to exhaust near the brake chambers. In this diagram a quick release valve is placed close to the front brake chambers between the foot valve and the air chambers.

*A **quick release valve** has been installed between the front brake chambers and the **foot valve**.*

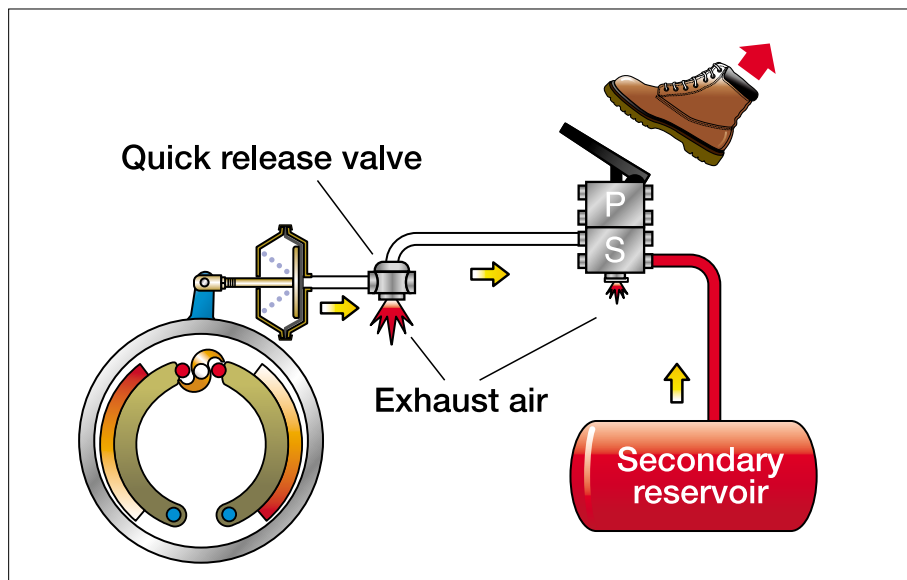

When the brakes are applied, air from the foot valve flows through the quick release valve to the chambers in the normal manner.

When the driver releases the foot valve, only the air in the line between the foot valve and the quick release valve is vented at the foot valve exhaust port. The larger volume of air contained in the air chambers is vented at the exhaust port of the quick release valve.

Note the difference in the air bursts at the foot valve and at the quick release valve – there is a much bigger burst of exhausting air at the quick release valve.

Quick release valves may be found in a number of places in an air brake system, including front brakes, rear brakes, spring parking brakes and any other place that the rapid exhausting of air is required.

Relay valve

A **relay valve** has been installed between the reservoir and the rear brake chambers.

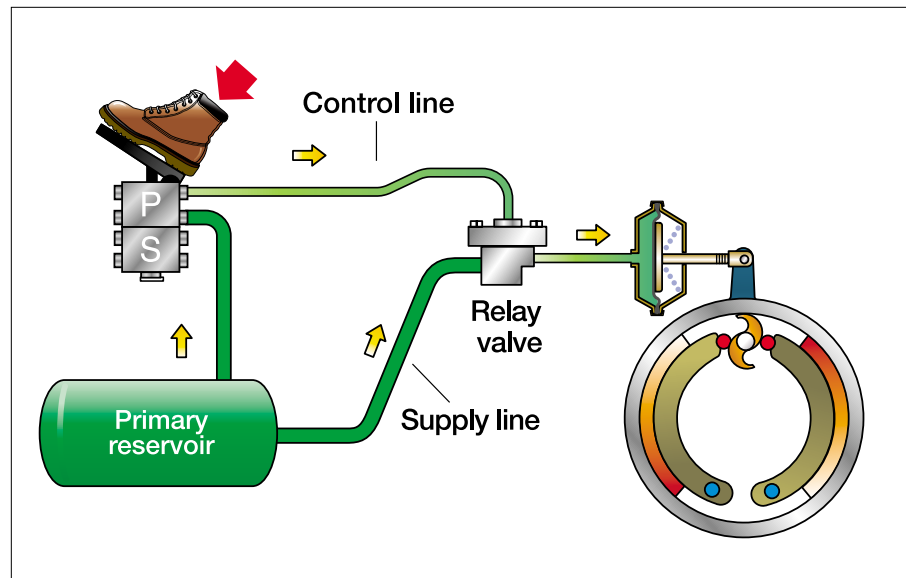

Relay valves are used to reduce the lag time when the brakes are applied, and when they are released. They are remote controlled air valves that respond to a control signal from the foot valve. They are usually mounted on a frame rail close to the air chambers that they are to operate.

Relay valves are supplied with air directly from the primary or secondary reservoirs through a large diameter air line (shown as the **supply line** in the diagram) so that there is a high volume of air available for rapid delivery to the air chambers.

The pressure of the reservoir air delivered in this way will be the same as the control pressure delivered by the foot valve. If you make a 20 p.s.i. (138 kPa) brake application, approximately 20 p.s.i. of air pressure would be directed to the rear brake chambers through the relay valve.

When the driver releases the foot valve, only the air in the control line is vented at the foot valve exhaust port. The volume of air contained in the air chambers is vented through an exhaust port built into the relay valve.

Relay valves are designed to handle the volume requirements of two or four air chambers. Though they are primarily found on rear axle brakes, relay valves are sometimes found on steering axle brakes or wherever there is a need to apply and release air rapidly.

For simplicity, quick release valves and relay valves are not shown in the following diagrams because they do not change the basic concept of an air brake system, but serve only to speed up the release of the brakes, if needed.

Dual System with Primary System Failure

This diagram shows the worst case failure where a line rupture has caused a total loss of pressure in the primary reservoir.

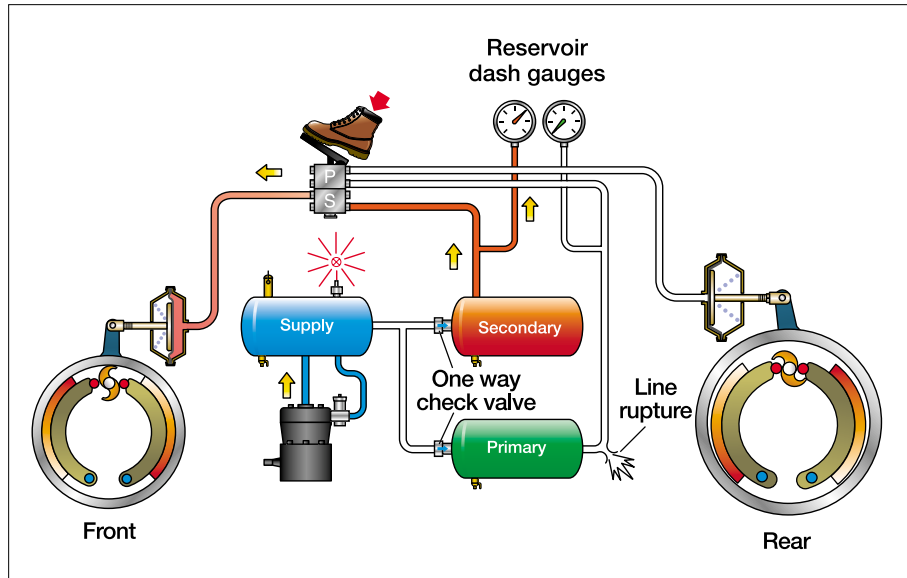

Despite a loss of primary reservoir pressure, the front (secondary) brakes will still operate.

Air pressure in the secondary reservoir has been protected by the one-way check valve. The low air warning system must activate when pressure in any reservoir falls below 60 p.s.i. (414 kPa) to alert the driver to the problem. In many systems, the warning will come on at pressure above 60 p.s.i.

When you apply the brakes, you will be able to make a controlled stop, but only the steering axle brakes will apply, and thus stopping distances will be longer because the braking force will be reduced.

If the failure had been in the secondary system, braking on the rear axle would have been maintained, but the steering axle brakes would not operate.

The compressor will continue to pump air, but all of its output will take the path of least resistance and be vented at the line rupture.

If the low air warning system activates at any time, **stop immediately** and do not proceed until a repair has been made.

Parking Brakes

While air pressure does an excellent job in helping to stop a vehicle by applying the foundation brakes, it is totally unreliable (and illegal) for parking. If a vehicle were to be parked using only the air brakes, any leaks in the system, or any failure in a hose, diaphragm, or air valve would result in loss of air pressure and a possible rollaway collision.

Regulations for parking brakes require that once applied, the parking force must be maintained by mechanical means and be unaffected by loss of air pressure.

The most common type of parking brake in an air brake system is the **spring parking brake**. The second type is known as a **safety actuator** and is usually found only on some highway coaches and intercity buses.

Spring Parking Brakes

Most spring parking brakes consist of an additional chamber attached to the rear of a service brake chamber. The added chamber contains a powerful coil spring arranged so that the spring force can be applied to the brakes through the normal service chamber pushrod.

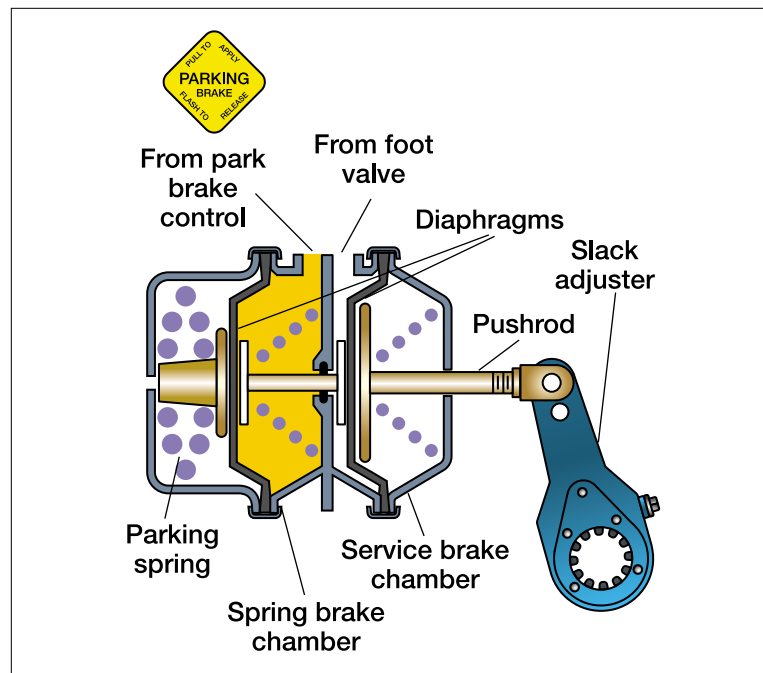

A spring parking brake chamber attached to a service brake chamber. The brakes are off.

Fast Fact

While the spring parking brakes will apply if air pressure falls beneath a certain level, their effectiveness in stopping the vehicle or holding a parked vehicle depends on how well the brakes have been kept in adjustment.

This concrete mixer has spring brakes on its tandem rear axles only — not on the twin steering axles, nor on the booster axle at the rear.



Warning

The spring in a spring parking brake is very powerful. If the spring were ever to break out of the chamber, it could cause serious damage to any objects or persons in its way.

Keep away from a spring parking brake chamber that shows any sign of damage, such as dents or cracks anywhere in the housing.

This diagram shows the main components of a typical combination spring and service brake chamber.

Spring parking brakes are mounted on the rear axles only – not on steering axles. The service brake chamber contains the normal pushrod, diaphragm and return spring. The spring parking brake section is mounted behind the service brake chamber.

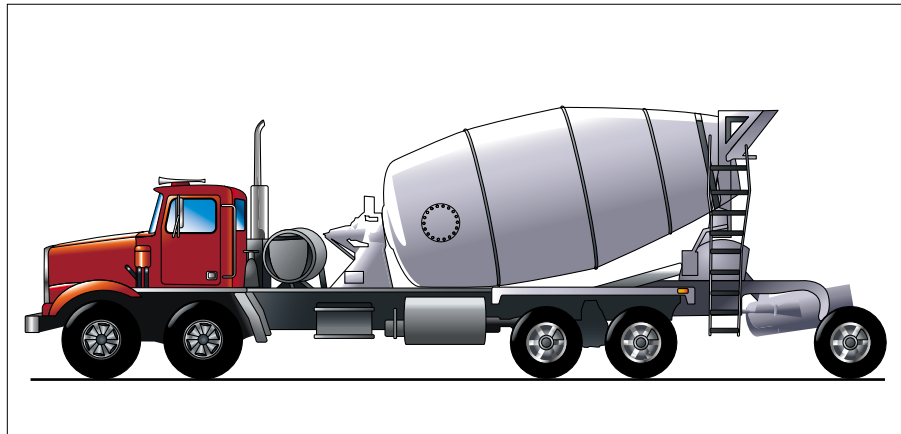

The spring parking brake chamber contains a second diaphragm, a large coil spring, and an intermediate pushrod that is used to transmit the force of the coil spring to the service brake pushrod when the spring parking brake is applied. The coil spring in most spring parking brake chambers can exert a force of between 1,500 and 2,000 pounds.

When you make a regular foot brake application, air pressure is applied against the diaphragm in a service brake chamber, causing the diaphragm to inflate, pushing the push rod out against the slack adjuster to apply the foundation brakes.

Spring parking brakes work in the opposite way. These brakes are applied and remain applied by mechanical spring pressure, not by air pressure. If air pressure falls beneath the amount needed to keep the spring compressed, the spring pushes against the push rod in the service brake chamber, pushing the push rod out against the slack adjuster to apply the foundation brakes (because the parking brake chambers are piggy-backed onto the service brake chambers and operate the foundation brakes through the same linkage).

Spring parking brake assemblies should only be serviced by qualified personnel. The spring in a spring parking brake chamber is under extreme pressure and could cause serious personal injury.



RoadSense Tip

In some systems, spring parking brakes will gradually apply as air pressure goes down, rather than apply all at once.

Air pressure in the spring parking brake chamber keeps the spring parking brake off. There is no air pressure in the service brake chamber.

Applying and releasing spring parking brakes

There are several ways to apply and release spring brakes.

- Normally they are applied and released by using the parking brake control valve on the dashboard.
- If the air pressure in the system falls below approximately 60 p.s.i., the spring brakes may begin to drag, and at 20 to 45 p.s.i. (138 to 310 kPa) may automatically fully apply.

Spring parking brake — released

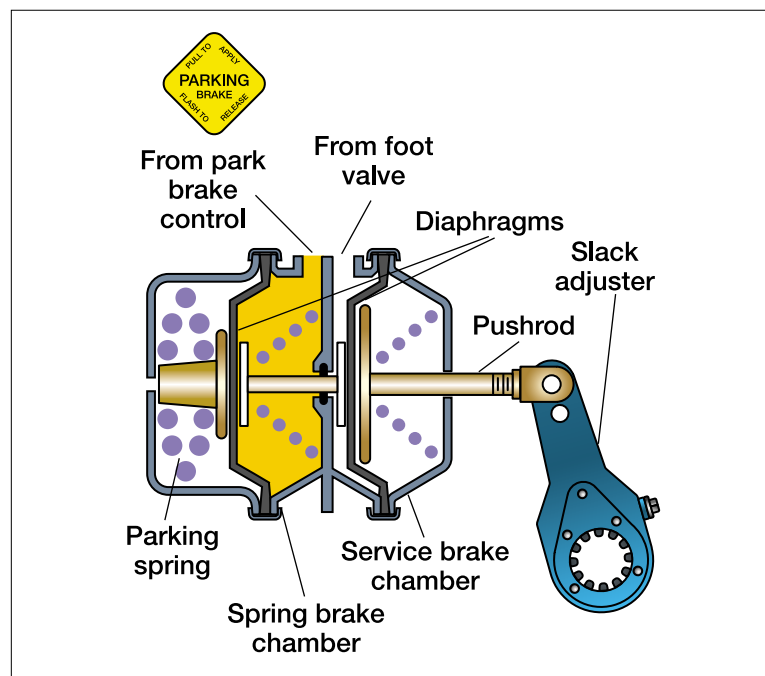

This diagram shows a spring parking brake chamber in the released position. The service brake is also in the released position.

Air at reservoir pressure has been supplied to the spring parking brake section. The parking brake diaphragm has inflated, compressing the main spring. The spring parking brakes are now released.

A **parking brake control valve** (usually a yellow button) is mounted on the dashboard. In most cases, pushing this valve in allows air pressure to flow to the spring parking brake chambers, causing these spring parking brakes to release. Pulling this valve out exhausts the air pressure against the spring parking brake chamber, causing these brakes to apply. Instructions are usually imprinted on the button.

While the push-pull parking brake control is the most common, some systems use a switch, usually set so that flipping it in one direction applies the spring parking brakes and flipping it in the other direction releases them.



A parking brake control valve.

Spring parking brake — service brake applied

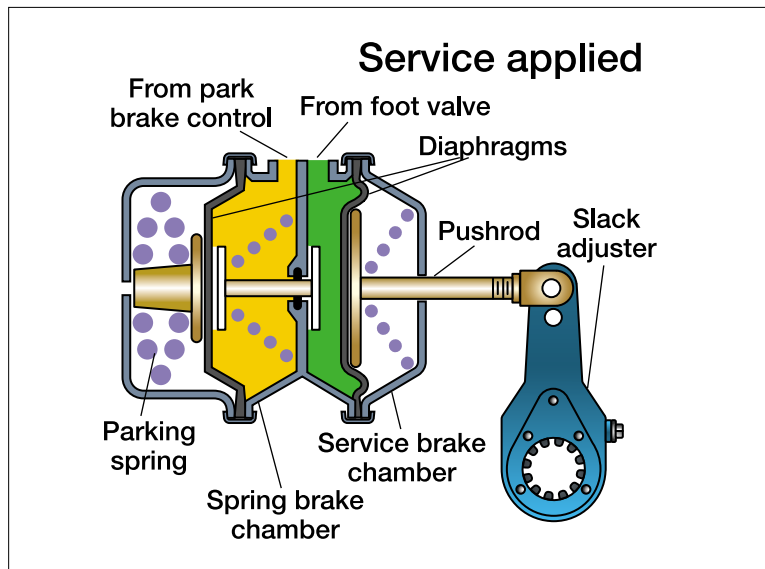

The driver has applied the service brake. Air pressure in the spring parking brake chamber keeps the spring parking brakes off.

The driver has applied the foot valve, delivering air to the service brake port, inflating the service brake diaphragm.

Spring parking brake — spring brake applied

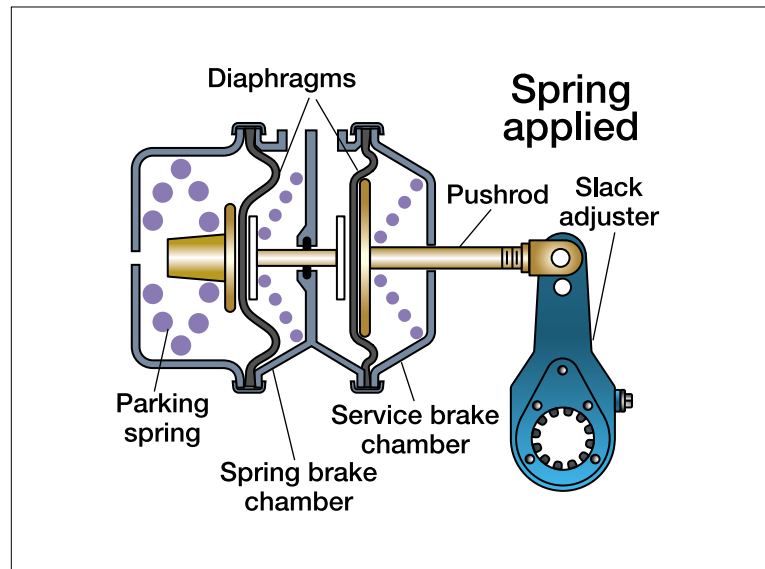

The driver has applied the spring parking brake. There is no air pressure in either the spring parking brake chamber or the service brake chamber.

The driver has placed the parking brake dash control valve in the “park” position. This has caused the air from the spring parking brake section to be exhausted.

The force of the coil spring has been transmitted to the intermediate pushrod, which in turn has pushed against the service brake diaphragm, pushrod, and slack adjuster, applying the brakes.

Driver alert — compounding of brakes

Always be sure that the spring parking brakes are released before making heavy service brake applications, such as those made during a pre-trip inspection.

When spring parking brakes are applied, there is up to 2,000 pounds of force applied to all of the brake components. If a heavy service brake application is made, the force of the air application is added to the spring force. This could add a further 3,000 pounds for a total of 5,000 pounds. This adding together of the two forces, known as **compounding** can cause damage to slack adjusters, s-cams, brake chamber mounting bolts, brake shoe rollers, shoes and brake drums.

Note that lighter brake applications of less than 30 to 40 p.s.i. (207 to 276 kPa), to prevent a vehicle from rolling while the spring parking brakes are being released or applied, are not harmful.



RoadSense Tip

Avoid compounding the brakes.

Always release the spring parking brakes before making a heavy service brake application.

Spring parking brake — manual release

Most spring parking brake chambers have a means of manually releasing, or “caging” an applied spring parking brake. This feature should only be used by mechanics when making a repair.

If all air is lost and the vehicle has to be towed, spring parking brakes can be released by caging them. Always block the wheels when caging spring parking brakes. Once a spring brake chamber is caged, there will be no parking brake force at that wheel.

Some chambers have a built-in release bolt while others have a release bolt, nut and washer carried in a bracket mounted on the chamber housing.

The spring has been caged using a caging bolt.

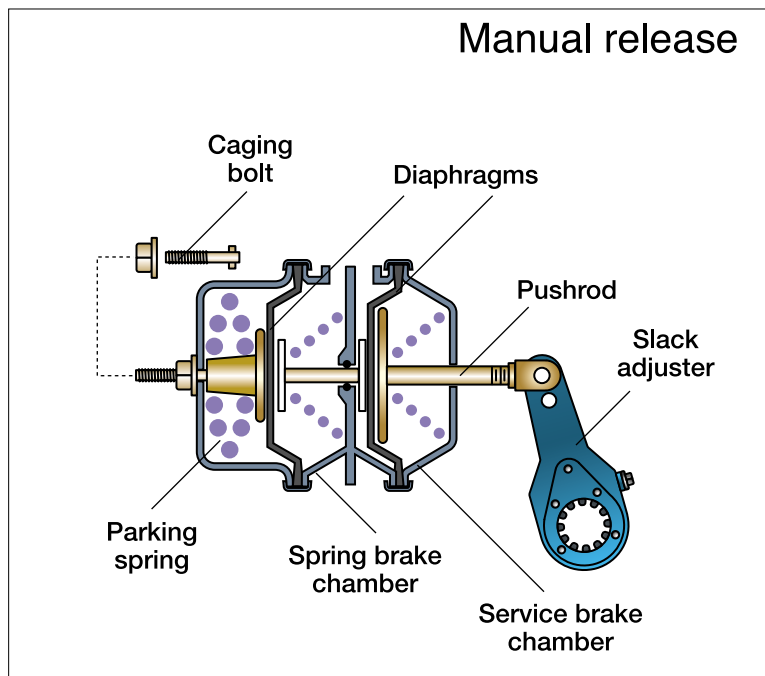

RoadSense Tip

Caging spring parking brakes should be done only in an emergency.

Once a spring brake chamber is caged, there will be no parking brake force at that wheel.

This diagram shows how one type of release bolt is inserted into the rear of the spring parking brake housing. The release bolt is then given a quarter turn to lock it in place. Then the release nut is turned until the spring is compressed.

Instructions for manual release are usually imprinted on the housing of most spring parking brake chambers.

Before attempting to manually release spring parking brakes, block the wheels to prevent the vehicle from rolling. To move a vehicle after manually releasing the spring parking brakes “call a tow truck!”

Spring parking brakes in dual air brake systems

This installation takes advantage of the primary and secondary reservoirs to supply the parking brake dash control with air from the tank that has the highest pressure.

Spring parking brakes installed in a dual air brake system. The brakes are off.

Fast Fact

The effectiveness of spring parking brakes depends on how well the brakes have been kept in adjustment.

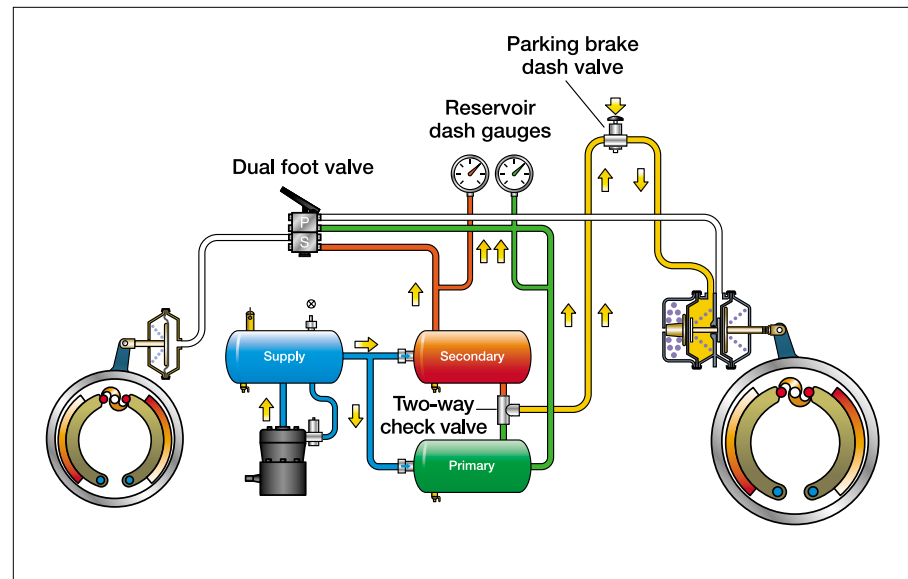

This is accomplished by the use of a **two-way check valve**. The air that is delivered from the two-way check valve is frequently called **blended air**.

Blended air

The two-way check valve draws air from the tank with the highest pressure.

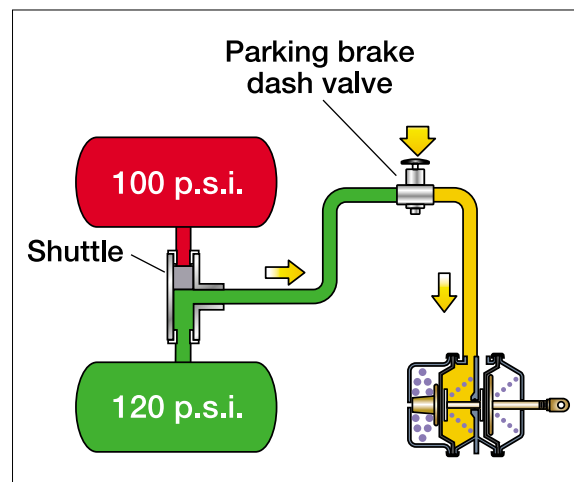

The two-way check valve has two inlet ports and one delivery port. A free floating shuttle within the valve will move away from the inlet that has the higher pressure, and the higher pressure will be supplied to the parking brake control.

This arrangement will also ensure that the spring parking brakes will not automatically apply if there is a total loss of air pressure in either reservoir.

Dual air brake system — partial system failure

Despite the ruptured air line from the primary reservoir, the driver can still make a controlled stop.

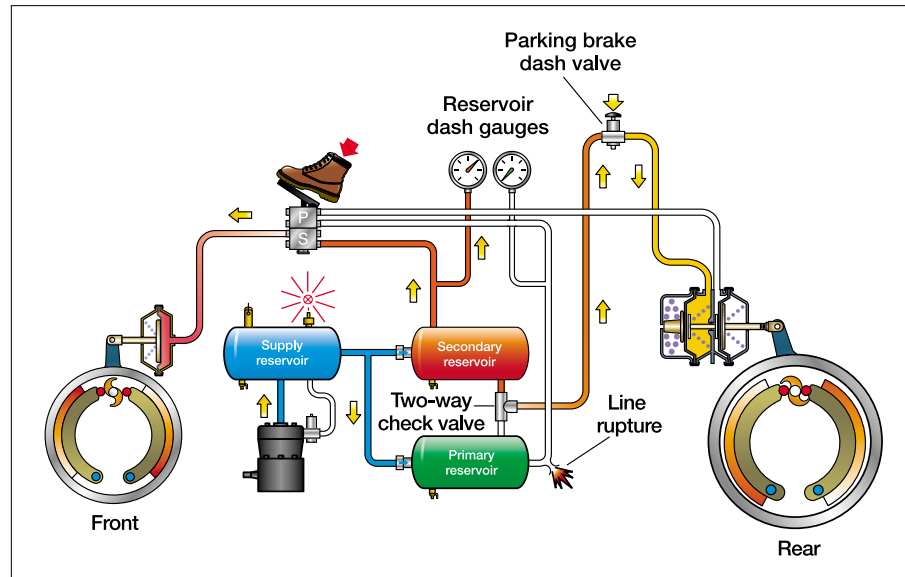

This diagram shows the benefit of the blended air supply for the parking brake system. There has been a loss of air from the primary reservoir. The two-way check valve shuttle has moved so that secondary reservoir pressure supplies the parking brake dash valve.

The result is that the spring parking brakes do not apply automatically. The low air warning system has alerted the driver to the air loss, allowing the driver to make a controlled stop using the front axle brakes.

Some vehicles with dual air systems are equipped with an optional device called a **spring brake modulator**. This device senses a loss of pressure in the primary system, and when the driver applies the service brakes, causes air to be exhausted from the spring parking brakes in direct proportion to the brake application. By simply applying the foot valve normally, the driver controls the amount of spring force used to assist the front brakes to bring the vehicle to a controlled stop.

All vehicles must meet Canadian Motor Vehicle Safety Standards for emergency stopping, so regardless of how the dual system is arranged, or if a spring parking brake modulator is installed, the vehicle will have adequate braking force, even with a partially failed air system.

With all systems, after stopping, the driver can securely park the vehicle by manually applying the parking brake dash control valve.

Safety actuator parking brakes

Safety actuator parking brakes are used on many buses and highway coaches. They are similar in appearance to spring parking brakes but their operation is very different.

Rather than using a powerful coil spring, this brake uses a one-way locking mechanism that can be engaged to allow the pushrod to stroke outward, but prevent it from returning. The actuators have two diaphragms, one to apply the service brake, and the other to apply the parking brake.

Safety actuator parking brake chambers are found on some buses.

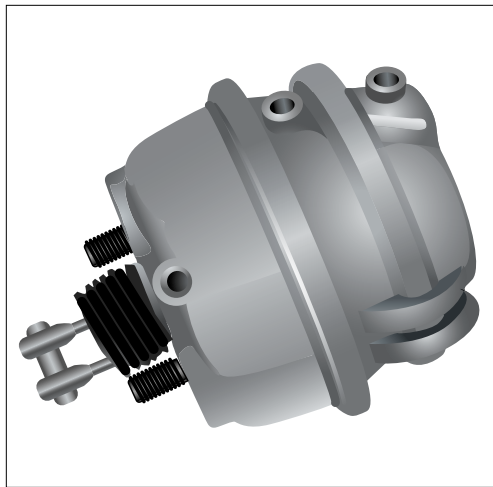

A separate air reservoir is used for parking and the parking brake dash control is identical in appearance and operation to the one used for spring parking brakes.

Pulling the dash control outward simultaneously applies air pressure to the parking diaphragm and engages the locking mechanism. The pushrod moves out, applying the brakes. The pushrod is then held in the applied position by the locking mechanism. The vehicle is parked securely, even if air is lost from all reservoirs.

Normally, pushing the dash control inward causes air to exhaust from the parking diaphragm and at the same time releases the locking mechanism, allowing the pushrod to retract. However, if more than 4 p.s.i. (27.6 kPa) pressure has been lost from the parking reservoir, the parking brakes will not release. A heavy service brake application must also be made, causing the pushrod to move slightly ahead, allowing the locking mechanism to disengage.

Because spring force is not used for parking, safety actuator parking brakes cannot be compounded.

Note that safety actuator parking brakes will not apply automatically, even if service reservoir pressure is drained or pumped down to zero. Only loss of pressure in the parking reservoir will cause automatic application.

Tractor-Trailer Air Brake Systems

To understand the basics of tractor-trailer air brake systems, it is best to start with the trailer. Once the trailer system is understood, it becomes simpler to understand the components that are needed to tow a trailer.

A trailer system has many of the components found on a truck system. Of course, the trailer must have foundation brakes, air chambers, air reservoirs and control valves. The only major item not found on a trailer air system is an air compressor.

The trailer system must rely on the tractor for two important needs. First, the trailer must receive the compressed air from the tractor to fill the trailer reservoirs. Second, the trailer system must receive the commands from the tractor as to when to apply, and when to release the brakes.

To fulfill these needs, there are two air line connections between the tractor and the trailer air systems.

The air line that supplies the trailer reservoirs with air at full tractor reservoir pressure is called the **supply line**. It is sometimes called the **emergency line**.

The line that carries the control signal from the tractor is called the **control line**. It is also commonly called the **service line**.

Because tractors and trailers need to be disconnected and reconnected from time to time, the air lines are equipped with quick coupling devices called **glad hands**. Each coupler resembles a human hand about to make a handshake to “give you the glad hand.” Glad hands are often colour-coded – a blue line or blue colouring on a glad hand is used to indicate the control line, and red is used to indicate the supply line.

Fast Fact

The supply line may also be called the emergency line.

The control line may also be called the service line.

Glad Hands allow easy and quick connection between the tractor and trailer.

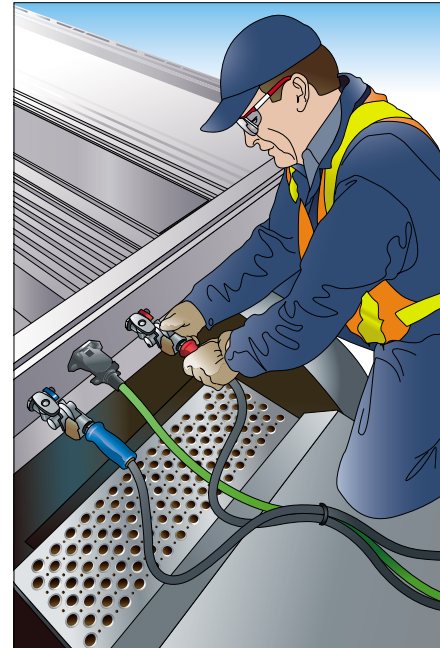
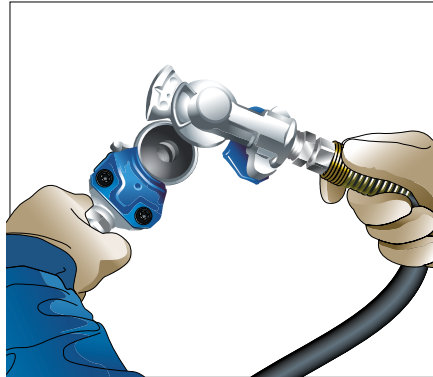

RoadSense Tip

When not in use, glad hands should be fastened to dead-end (dummy) couplers or to each other to prevent dirt and debris from entering the air lines.

Glad hands should also be secured to prevent the lines from chafing against other components or bouncing off the vehicle.

There are two basic types of trailer air systems – those that use spring parking brakes and those that do not. Although most current trailers do use spring parking brakes, there are a number of earlier trailers and converter dollies in use that are not equipped with spring parking brakes.

All trailer systems, with spring parking brakes or without, must have an emergency stopping system that will fully apply the trailer brakes in the event that the trailer separates from the tractor.

Trailers that are not equipped with spring parking brakes use a device called a **relay emergency valve**. If this valve senses that the trailer has broken away from the tractor, it applies the trailer service brakes with full trailer reservoir pressure. This action is called **dynamiting** the trailer brakes.

Trailers equipped with spring parking brakes use the spring force to apply the brakes (dynamite the trailer brakes) if the trailer breaks away from the tractor.

Trailer with relay emergency valve — charging

The diagram shows a trailer equipped with a **relay emergency valve**. Air is passing from the tractor through the supply line to the relay emergency valve, filling the trailer reservoir.

Compressed air from the tractor flows through the supply line to fill the trailer reservoir.

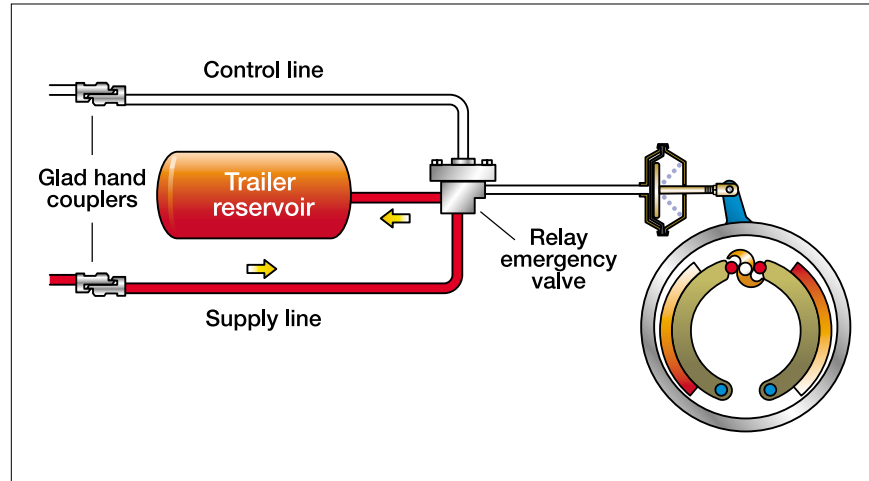

Trailer with relay emergency valve — applying

This diagram shows a normal service brake application. A control signal from the tractor has been sent through the control line to the relay emergency valve, which reacts to this signal in exactly the same way as the tractor relay valve previously described.

When the driver makes a brake application, air flows through the control line.

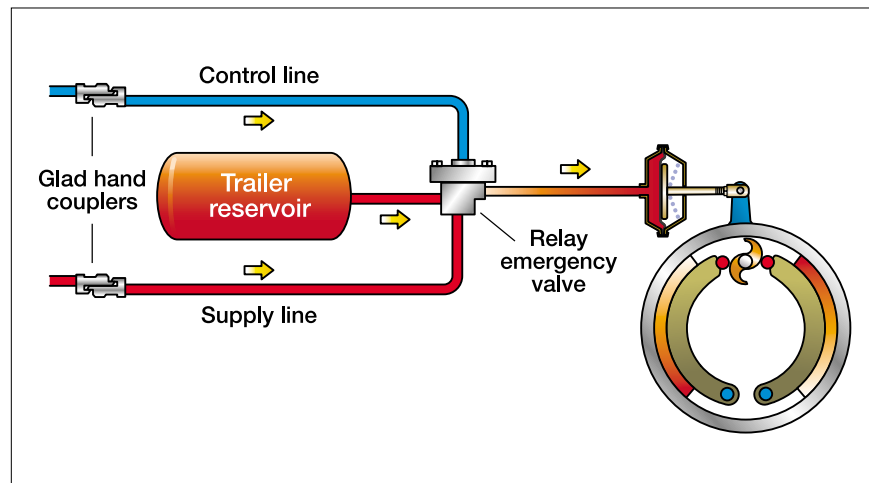

The relay emergency valve has drawn air from the trailer reservoir and delivered it to the trailer service chambers at approximately the same pressure as the control signal.

On highway trailers, one reservoir and one relay emergency valve are used for single or tandem axles. Some tandem logging trailers are equipped with a reservoir and a relay emergency valve for each axle.

Trailer with relay emergency valve — dynamited

This diagram shows a broken supply line. The relay emergency valve has sensed the loss of pressure in the supply line, and has delivered full trailer reservoir pressure to the service brake chambers, dynamiting the brakes. The trailer brakes will remain applied as long as pressure is retained in the trailer reservoir.

The broken supply line has caused the trailer brakes to dynamite.



Warning

Small leaks in trailer systems not equipped with spring parking brakes can cause the applied pressure to be reduced or depleted, possibly allowing a parked trailer to roll away.

Always block the wheels of a parked trailer to ensure it cannot roll.

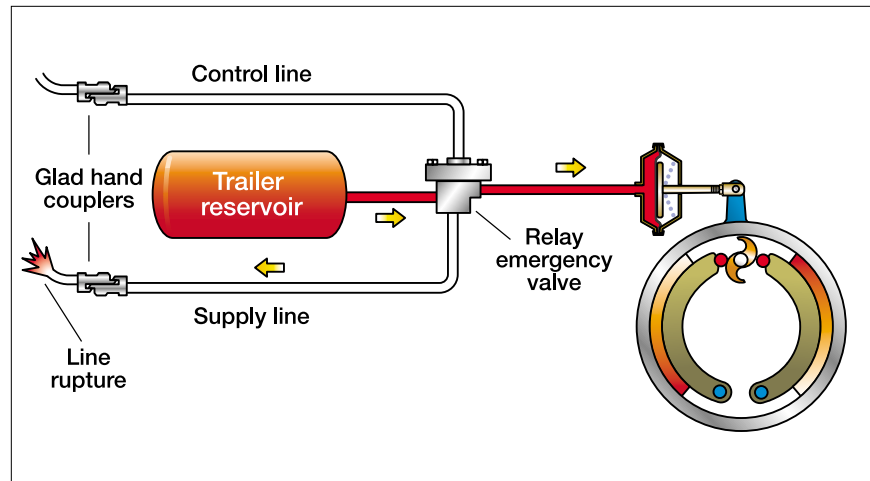

The trailer brakes will also be dynamited each time the glad hands are disconnected, or when the driver closes the trailer supply valve that is located on the tractor dashboard.

Motor vehicle safety standards require that these systems remain applied for a minimum of 15 minutes.

It is important to follow proper procedures when coupling a tractor to a parked trailer to prevent the trailer from moving and possibly causing damage. Coupling procedures are detailed in **Chapter 4 – Skills for Driving Trucks and Trailers.**

This trailer is equipped with spring parking brakes.



RoadSense Tip

You can usually tell if you have reversed the supply line and service line connections:

- the spring parking brakes will not release even when you use the parking brake control on the dashboard
- the trailer service brakes will not function

Avoid these situations by taking care in coupling to a trailer.



RoadSense Tip

Always perform a tug test after coupling the tractor to a trailer.

Before conducting a tug test, use a flashlight to visually check that the fifth wheel locking jaws are closed and locked.

Trailer with spring parking brakes — charging

This diagram shows a typical trailer system that uses spring parking brakes for parking and for emergency (breakaway) stopping.

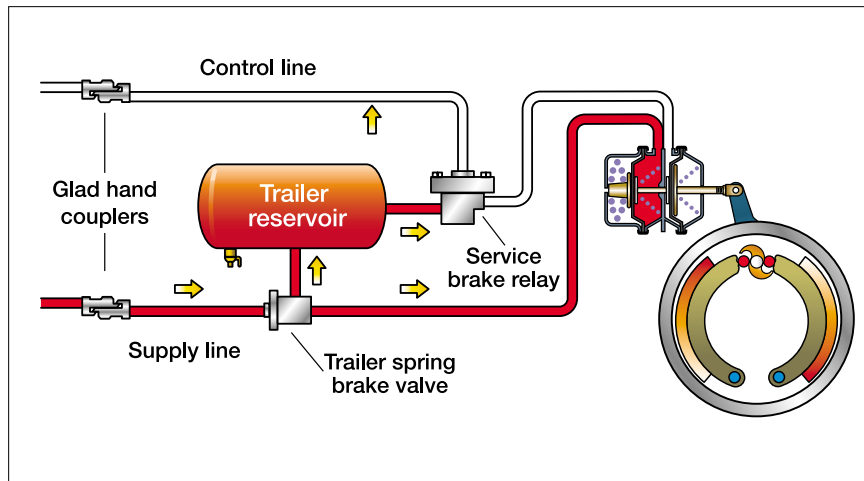

The system shown uses one reservoir and two air valves, a **relay valve** for the service brakes, and a **trailer spring brake valve** that fills the reservoir and controls the spring parking brakes.

Other systems may be equipped with one, two or three air valves and multiple reservoirs. However, the use of more or less air valves or additional reservoirs will not alter the basic operation of the system.

The tractor is delivering air through the supply line to the trailer spring brake valve. The spring parking brake valve directs air to fill the reservoir(s) and to release the spring parking brakes.

There are two types of systems:

- One type fills the reservoir(s) before releasing the spring parking brakes.
- The other type releases the spring parking brakes first, then fills the reservoir(s).

Always perform a tug test after coupling the tractor to the trailer. Follow the coupling procedures as shown in **Chapter 4 – Skills for Driving Trucks and Trailers**.

Trailer with spring parking brakes — service brake application

In the diagram, a control signal from the tractor has been sent through the control line to the trailer’s relay valve. The relay valve has drawn air from the trailer reservoir and delivered it to the trailer service brake chambers at approximately the same pressure as the control signal.

The trailer brakes have been applied by pressing on either the foot valve or applying the hand valve, or both.

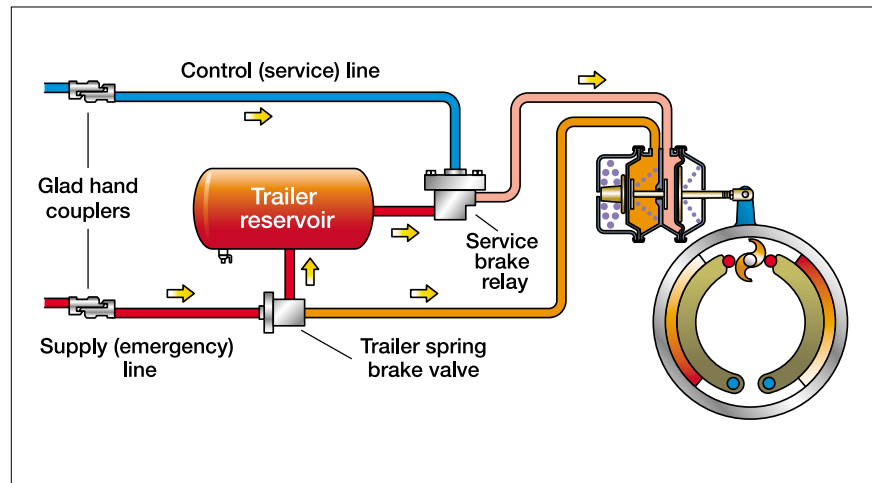

Trailer with spring parking brakes — dynamited

This diagram shows a broken supply line. The trailer spring brake valve has sensed the loss of pressure in the supply line and has exhausted the air pressure from the spring parking brake chambers, causing the spring parking brakes to apply. Note the burst of air from the exhaust port of the trailer spring brake valve.

The supply line has broken, causing the trailer spring parking brakes to apply.

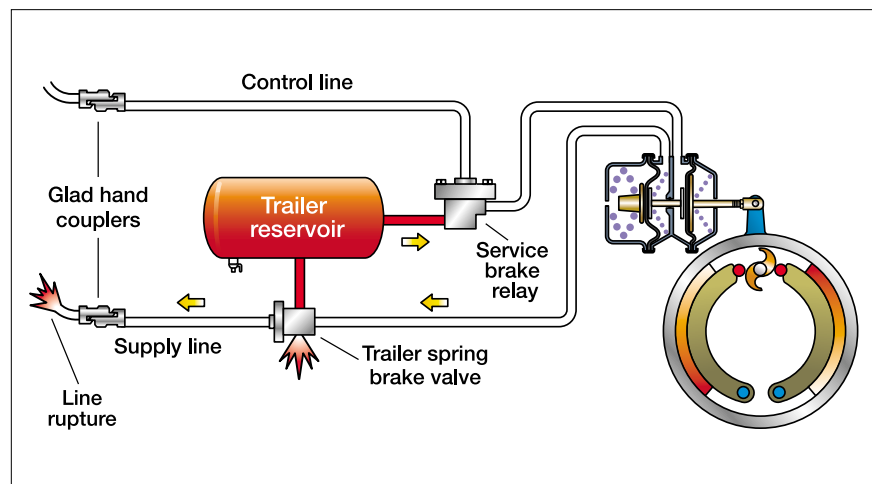

This action can also be called dynamiting of the trailer brakes. The trailer brakes will also be dynamited each time the glad hands are disconnected, or when the driver closes the trailer supply valve that is located on the tractor dashboard.

Fast Fact

A peace officer may place your vehicle out of service if the tractor protection system allows the tractor pressure to drop below 20 p.s.i. (138 kPa) without the trailer air supply valve automatically closing.

Tractor protection

If the mechanical connection between the tractor and trailer were to fail, causing the trailer to separate from the tractor, the two connecting air lines would break. Air pressure from the tractor system would rush out through the broken supply line, and if the driver were making a brake application, air pressure would also rush out through the broken control line.

To prevent the tractor air from being depleted to an unsafe level, tractors are equipped with a **tractor protection system**.

A tractor protection system consists of a **trailer air supply valve** located in the tractor dash, and a **tractor protection valve**, usually located behind the tractor cab. All of the supply and control air delivered to the trailer passes through the tractor protection valve.

In the event of a trailer breakaway, the tractor protection system will automatically shut off air loss from the tractor, preserving enough pressure for the driver to make a safe stop.

Some tractor protection systems will shut off immediately in the event of a breakaway, but some will allow tractor pressure to drop to as low as 20 p.s.i (138 kPa) before shutting off.

Proper operation of the tractor protection system should be checked as part of the daily pre-trip inspection.

Trailer air supply valve

Once the supply line is connected to the trailer, there needs to be a way of directing air pressure to the trailer.



Trailer air supply valve

This is the job of the dash mounted **trailer air supply valve**. It senses air pressure in the supply line that carries air to the trailer system. Most trailer air supply valves are an octagon-shaped red button.

Hand valve

There are times when it may be beneficial to apply only the trailer brakes without applying the tractor brakes, such as when coupling the tractor to a trailer.

The hand valve allows independent control of the trailer brakes. Some are mounted on the steering column, others are mounted in the dashboard.



Warning

Do not use the hand valve for parking — air pressure may bleed off if the engine is stopped, or in the case of a spring-loaded hand valve, it may return to the “off” position.

When parked, close the trailer supply valve and block the trailer wheels.

This is the purpose of the **hand valve**. When the trailer air brake system is fully connected to the tractor, the hand valve allows you to apply the trailer brakes independently of the tractor.

The hand valve should not be used in normal or emergency situation braking. Always use the foot valve for service braking.

Most hand valves are spring-loaded, just like the foot valve, so that when you release it, it will return to the released position.

Two-way check valve

The **two-way check valve** allows you to apply the trailer brakes independently. This valve is identical in construction to the one used in spring parking brake installations, except that it allows the highest application pressure from the hand valve or the foot valve to be directed to the trailer brakes.

Bobtail tractors

Driving a tractor without a trailer attached is called **bobtailing**.

Driving a tractor without a trailer attached is called bobtailing.

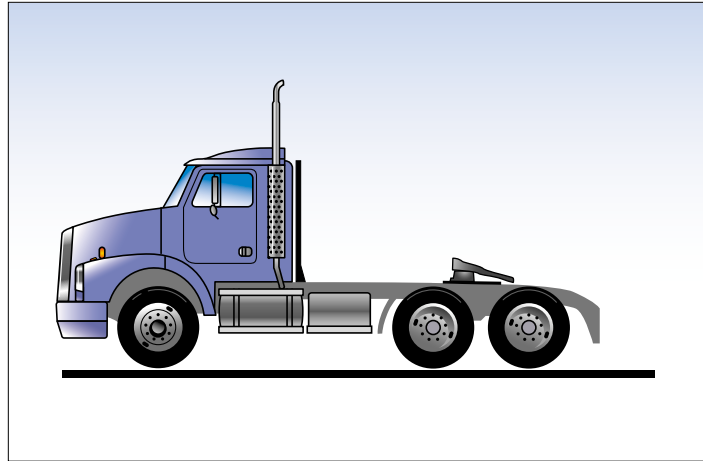

Because a bobtail tractor has very little weight over the rear drive axles, it is very easy to lock up the rear brakes, even with a light brake application.

To help prevent this unwanted lockup, and to increase control, some tractors are equipped with a **bobtail proportioning system**.

This system consists of two special valves, one controlling the steering axle brakes, and the other controlling the drive axle brakes.

When the tractor is being driven with a trailer attached, the tractor brakes operate normally.

When bobtailing, the braking pressure to the drive axle brakes is reduced by as much as 75 per cent, preventing the rear brakes from locking.

At the same time, the steering axle brakes receive full application pressure.

A tractor with a bobtail proportioning system will stop in a shorter distance and control will be increased, especially on wet or slippery road surfaces.

Because the steering axle brakes are doing most of the braking, a higher than normal pedal pressure is required.

Dual air tractor-trailer system — foot valve applied

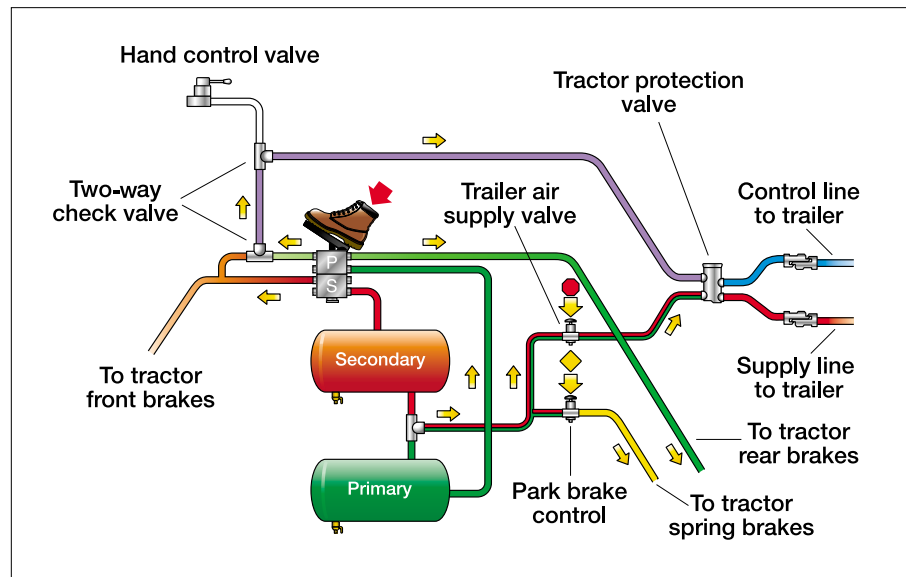

A dual air tractor system for towing a trailer.

This diagram shows only the two service reservoirs, the dual foot valve, and the components that are added to a tractor with a dual air system so that it can safely tow a trailer with air brakes.

The same trailer supply valve, tractor protection valve, hand valve and two-way check valve that were added to the truck with the simple air system are used.

An additional two-way check valve is installed so that air from the section of the dual foot valve that delivers the highest pressure will be sent to the trailer control line.

The driver is making a foot valve application. The tractor front and rear brakes are being applied, and a control signal is being sent to the trailer through both of the two-way check valves.

Note that in most dual systems, the parking brake control valve (yellow button) is interlocked with the trailer supply valve (red button) so that applying the parking brake control valve causes all of the parking brakes on both the tractor and trailer to apply.

Some tractors are equipped with three dashboard control valves – the parking brake control valve (yellow button), the trailer supply valve (red button), plus a **tractor parking brake valve** with a round blue button that can control the tractor parking brakes independently of the trailer brakes.

Dual tractor-trailer system — primary air system failure

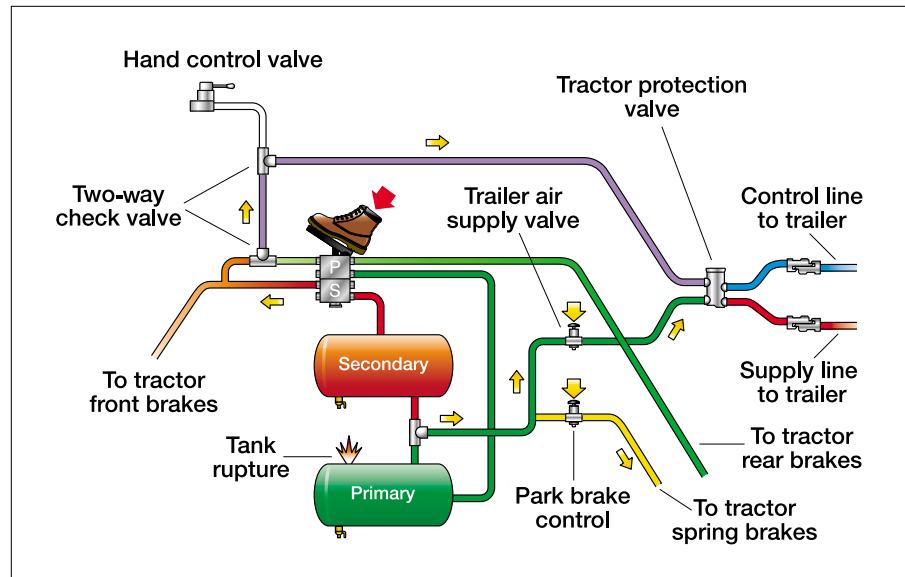

Despite the ruptured air line from the primary reservoir, the driver can still make a controlled stop.

Fast Fact

A peace officer may place a trailer out of service if the trailer brakes do not apply when the trailer air supply valve is closed.

This diagram shows a tractor with a dual air system where there has been a failure in the primary air system on the tractor. The low air warning would have alerted the driver to the problem and a glance at the reservoir gauges would confirm that only one part of the dual air system had been lost.

The driver is making a foot valve application, causing the tractor front brakes to apply. Application air from the secondary foot valve is also passing through both of the two-way check valves, to the trailer control line, signalling the trailer brakes to apply.

If it were the secondary system that had failed, a foot valve application would apply the rear tractor brakes, directing air through both of the two-way check valves to signal the trailer brakes to apply.

The same motor vehicle safety standards that require automatic shutoff of the air supply to the trailer – in the event that the pressure in the tractor air system is lowered to between 20 and 45 p.s.i. (138 and 310 kPa) – apply equally to tractors with dual air systems.

Because the trailer supply valve is now supplied with “blended air” from a two-way check valve, the automatic shutoff will not occur until the service reservoir with the **highest** pressure is lowered to between 20 and 45 p.s.i. (138 and 310 kPa).

The automatic shutoff requirement should be checked as part of a pre-trip inspection. If it doesn’t function properly, the vehicle must be placed out of service until it is repaired.

Dual tractor-trailer system — trailer breakaway

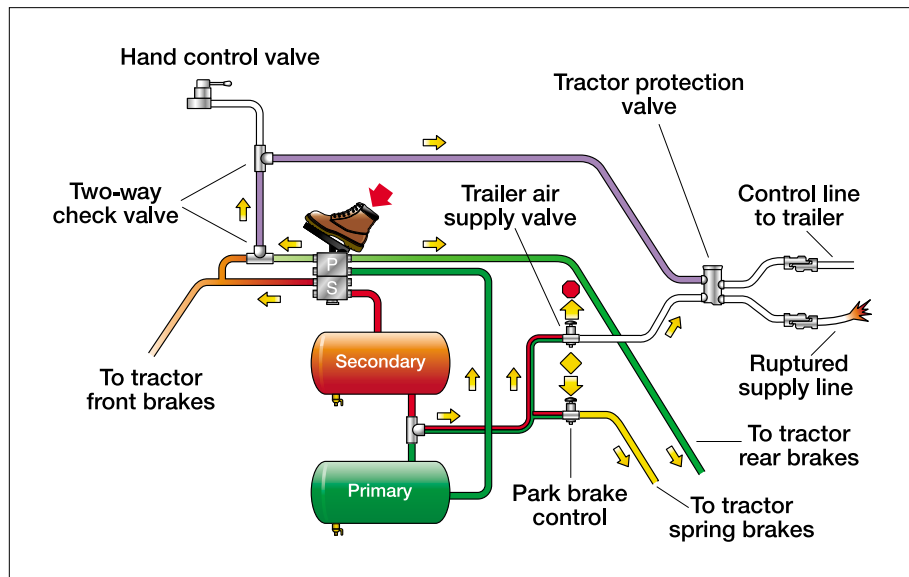

Despite the ruptured supply line, the driver can still make a controlled stop.

This diagram shows how the tractor protection valve and the trailer air supply valve act together to protect the tractor air supply from being depleted to an unsafe level in the event that the trailer separates, causing the connecting lines to rupture. The sudden loss of air through the broken trailer supply line has caused the trailer air supply valve to shut off automatically.

The driver is making a foot valve application, causing the tractor service brakes to apply. The application pressure is also passing through both of the two-way check valves to the tractor protection valve.

Because there is no pressure in the supply line to the trailer, the tractor protection valve has closed the passage to the trailer control line, so no application air can be wasted through that broken line.

If the control line separates, nothing will happen until the trailer brakes are applied. When that happens, the tractor protection system will activate to protect the tractor air supply.

When no trailer is connected, the trailer air supply valve will be in the closed position, allowing the tractor to be driven bobtail so that no air will be wasted through the disconnected glad hand couplers.

Other types of foundation brakes

There are three other types of foundation brakes found on air braked vehicles. These are:

- wedge brakes
- air disc brakes
- air-over-hydraulic brakes

Wedge brakes

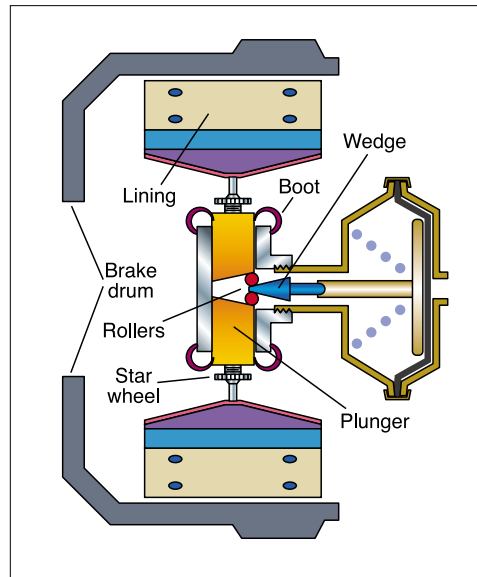

A typical wedge brake.



RoadSense Tip

Wedge brakes should only be adjusted or repaired by a qualified mechanic.

This type of brake uses one or two small air chambers with wedge-shaped pushrods. Once quite common on drive and trailer axles, wedge brakes are now usually found only on steering axles.

When the brakes are applied, air pressure in the brake chamber pushes the wedge part of the pushrod between two rollers, forcing the brake linings out to contact the brake drum.

Most wedge brakes have internal automatic adjusters. Checking proper adjustment requires that inspection hole covers in the backing plate be removed so that brake linings movement can be checked while the brakes are applied and released. If either linings move more than $\frac{1}{16}$ of an inch, or a total of $\frac{1}{8}$ of an inch for both linings, the automatic adjusters have failed.

Unlike conventional s-cam braking systems, drivers can't easily check the wedge brake adjustment of a wedge brake.

Adjustment and repairs to wedge brakes should only be carried out by a qualified mechanic.

Air disc brakes

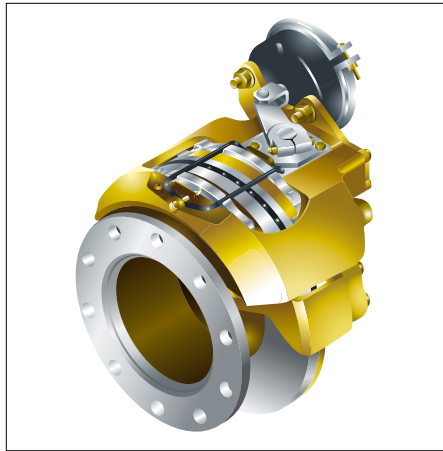

An air disc brake



RoadSense Tip

Air disc brakes should only be adjusted or repaired by a qualified mechanic.

This type of brake uses a rotor, or disc, that is mounted to the wheel hub and rotates with the wheel. Two brake pads are located on either side of the rotor. When applied, the brake pads are pressed against the rotor. This action is similar to that of a large “C” clamp.

There are a number of different linkages used between the air chamber and the operating mechanism. This illustration only shows one type, although the principle of the others is similar.

Most air disc brakes feature an internal automatic brake adjustment mechanism to adjust for brake pad wear. Chamber stroke limits are the same as for automatic slack adjusters.

Unlike conventional s-cam braking systems, drivers can’t easily check the adjustment of an air disc brake.

Adjustment and repairs to air disc brakes should only be carried out by a qualified mechanic.

Air-over-hydraulic brakes

Air-over-hydraulic brakes are frequently found on middleweight trucks and buses. This type of braking system combines the features of an air brake system with that of a hydraulic braking system.

Hydraulic foundation brakes offer several advantages on commercial vehicles of this size, including light weight, compact size and proven automatic adjusting mechanisms.

Most middleweight commercial vehicles of this size were once powered by gasoline engines, which supplied a source of engine vacuum so that vacuum boosters for the hydraulic brakes could be used. The now common diesel engine does not supply a usable vacuum, so a partial air brake system has been adopted.

An air-over-hydraulic braking system

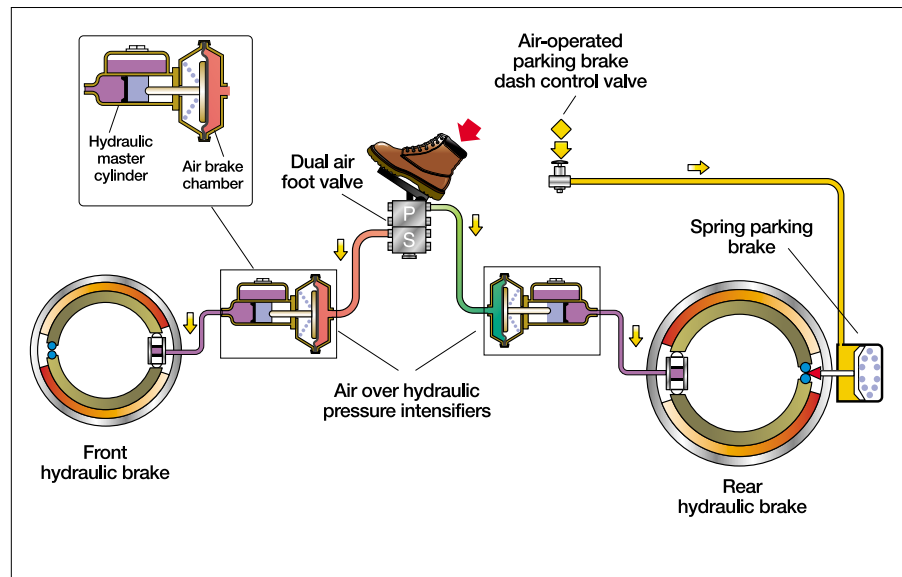

Fast Fact

An air brake endorsed driver's licence is required to operate most vehicles equipped with air-over-hydraulic brakes.

The only exception is if the brake system does not use an air treadle. In this case, an air brake-endorsed driver's licence is not required.

An air-over-hydraulic braking system, such as shown above, consists of a compressor, governor, air storage tanks, foot valve and two air-over-hydraulic **pressure intensifiers**. The system may also include spring parking brakes. Like a full air brake system, typical air-over-hydraulic braking systems use a standard air pressure of around 125 p.s.i. (862 kPa).

A standard dual air foot valve is used. Pressing on the foot valve directs air pressure to the air-actuated side of the hydraulic pressure intensifiers, causing the hydraulic-actuated side of the intensifiers to direct hydraulic pressure to the foundation brakes. In other words, air pressure actuates the braking action, but hydraulic pressure delivers the braking force to the foundation brakes to stop the vehicle.

To provide a parking brake, many air-over-hydraulic braking systems have a parking brake chamber attached to the foundation brake.



RoadSense Tip

Check gauges frequently to make sure there is adequate air pressure to apply the brakes.

The parking brake is controlled by the same dashboard-mounted parking brake control valve used on vehicles with full air brake systems.

Applying the parking brake control valve on the dashboard applies the spring in the parking brake chamber, which forces a wedge between the brake shoes, thereby applying the brakes. Releasing the parking brake control valve directs air pressure to the parking brake chamber to contract the wedge and spring.

Like a full air brake system, if there were a serious air leak in an air-over-hydraulic system, eventually the brakes would cease to function properly. For this reason, drivers need to know and understand how the system works, and check air pressure gauges frequently.

Other Air Brake System Components

The following are other components commonly found in air brake systems.

Air dryers

Air dryers are optional devices that are installed in the compressor discharge line between the compressor and the first reservoir. They are designed to remove any water vapour, oil mist and carbon particles from the air before it is delivered to the first reservoir.

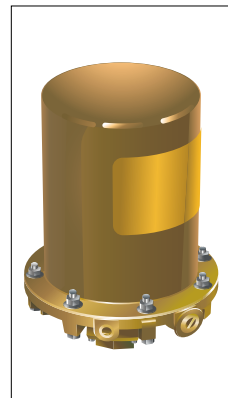

The warm, moist air from the compressor enters the dryer where a certain amount of the water vapour condenses on cool metallic surfaces. The air then passes through a filter that removes any oil and through another filter that removes the remaining water vapour. From there the clean air passes through an internal one-way check valve, and on to the first reservoir.

When the reservoir has come up to full pressure, a purge port in the bottom of the air dryer will open. The collected contaminants are ejected along with a sudden burst of air.

At the same time, a certain amount of clean air is allowed to flow back through the filters. This reverse flush effect cleans both filters in readiness for the next compression cycle. The purge port remains open until the compressor resumes pumping.

Some air dryers are equipped with an electric heating element to prevent freezing in cold weather.

In systems with an air dryer, the safety valve is often installed at the air dryer rather than at the supply reservoir.

Air dryer operation can be checked by periodically looking for water in the reservoirs. More than a few drops may indicate that the air dryer or compressor requires servicing.

Most new air brake systems include an air dryer.

Fast Fact

Even if the air brake system includes an air dryer, air reservoirs should still be drained regularly to check for contaminants.



RoadSense Tip

If you notice more than just a few drops of water when you drain the supply reservoir, the air dryer or compressor may need servicing.

Fast Fact

Even if the air brake system includes an alcohol evaporator or alcohol injector, air reservoirs must still be drained regularly.

Alcohol evaporators and alcohol injectors

Alcohol evaporators and **alcohol injectors** are optional devices that introduce a small amount of alcohol vapour into the air system. The alcohol vapour combines with any moisture that may be present. In effect, the alcohol acts as an anti-freeze, lowering the freezing point of any moisture that has collected in the air system.

Alcohol evaporators are connected to the inlet side of the compressor so that alcohol vapour is drawn in and compressed along with the intake air, which is then carried throughout the system.

Alcohol injectors are installed in the compressor discharge line between the compressor and the supply reservoir. The discharge air passes through a venturi (a tube with a narrow section, which causes air flowing through the tube to create a vacuum), picking up alcohol vapour and carrying it throughout the system.

An alcohol evaporator bottle



RoadSense Tip

Only use products specifically designed for use in air brake systems in alcohol evaporators or alcohol injectors.

The alcohol reservoir should be kept topped up with methyl hydrate during the winter months and it is a good practice to begin before the first freeze of the season to ensure trouble-free operation.

These systems are designed to use pure methyl hydrate to provide the alcohol and be sure to use only methyl hydrate specifically formulated for use in alcohol evaporators or alcohol injectors.

Automatic drain valves

Automatic drain valves, sometimes called “spitter valves” are optional devices installed on some or all of the reservoirs on some air brake systems. They intermittently expel any contamination that has collected.

Most are self-contained and momentarily open each time reservoir pressure lowers two or three p.s.i. (13.8 or 20.7 kPa), but some are connected to the compressor governor and momentarily open each time that the compressor cycles.

Some automatic drain valves are equipped with an electric heating element to prevent freezing in cold weather.

All automatic drain valves incorporate a manual means of checking for the presence of moisture in the reservoirs.

The manual drains should be opened periodically to check for the presence of water in reservoirs.

As mentioned previously, if more than a few drops of water are found, or if contaminants are found, the compressor or air dryer may need servicing, or the automatic drain valve may not be functioning correctly.

Front wheel limiting systems

On some vehicles, an optional system is installed to reduce the possibility of steering axle brake lockup and resultant loss of steering control on slippery surfaces. There are two types of front wheel limiting systems:

- automatic front wheel limiting systems
- manual front wheel limiting systems

Automatic front wheel limiting systems

An **automatic front wheel limiting system** consists only of a limiting valve, sometimes called a ratio valve, mounted near the steering axle. There is no dashboard control.

At very low application pressures, no air pressure is delivered to the steering axle brakes. As application pressure exceeds the holdback point (five to 15 p.s.i. – 34.5 to 103 kPa), limited application pressure is delivered to the steering axle brakes. At brake application pressures below 40 p.s.i. (276 kPa), the steering axle brake pressure is approximately 50 per cent of drive axle pressure.

At application pressures above 40 p.s.i., the percentage gradually rises, until at an application pressure that may be used during an emergency stop (60 to 70 p.s.i. – 414 to 483 kPa), steering axle and drive axle brakes receive equal pressure. A built-in quick release function helps to speed up the release of the steering axle brakes.

A manual front wheel limiting control.



RoadSense Tip

On vehicles equipped with a manual front wheel limiting valve, keep the control in the normal (Dry Road) position to have normal braking efficiency.

Under the *Motor Vehicle Act*, the Slippery Road position valve may only be used when weather conditions make its use essential for safety.

Fast Fact

Spring parking brake emergency release systems are sometimes called “California spring parking brake systems”.

Manual front wheel limiting systems

Manual front wheel limiting systems are no longer installed on new vehicles. This type of system consists of a limiting quick-release valve mounted near the steering axle brakes, and a dash mounted control valve. The control valve may be a “flip” type switch, as shown, or a push-pull type.

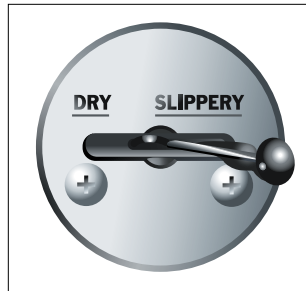

With the control valve in the “dry” position, the steering axle brakes are applied with the same pressure as the drive axle brakes.

In the “slippery” position, the application pressure to the steering axle brakes is limited to 50 per cent of drive axle brake application.

Commercial vehicle safety standards permit reduced braking on steering axle brakes only when weather and road surface conditions make such operation essential to safety. Tests have shown that front wheel skids do not have as dangerous an effect as do the drive axles locking up.

The limiting quick release valve also acts as a normal quick release valve, helping to speed up the release of the steering axle brakes.

Spring parking brake emergency release system

This system provides a special emergency release tank that can be used to release spring parking brakes if a disabled vehicle needs to be moved to a safe parking area and its main reservoir pressure is lost.

A second dashboard control valve is added so that air from the emergency release tank can be directed to the spring parking brakes to release them. This control valve is usually a “dead man” type that must be held in place while the vehicle is being moved. Once the vehicle has been moved, the spring parking brakes are re-applied by releasing hand pressure from the control.

Instructions for operating the emergency release system are usually found on the control valve or on a decal on the dashboard.

The popularity of this system was reduced with the introduction of the dual air system, but it is still sometimes used on transit buses, school buses and fire trucks.

Pressure protection valves

Pressure protection valves are frequently installed between the service brake reservoirs and any non-essential air-operated accessories such as air seats, air horns, air windshield wipers, air suspensions, fifth wheel sliders and air shifts. Some air brake systems integrate the air dryer with the supply reservoir – these also use pressure protection valves.

They are designed to cut off the air supply to these systems if a failed accessory causes the service reservoir pressure to drop below a preset

pressure, ensuring that sufficient pressure is maintained in the service system so that a safe stop can be made.

Shutoff pressures vary between 60 and 90 p.s.i. (414 and 620 kPa), depending on the manufacturer's specifications.

Application pressure gauges

Some trucks and tractors are equipped with one or more optional gauges that indicate the actual pressure being delivered to the service brakes.

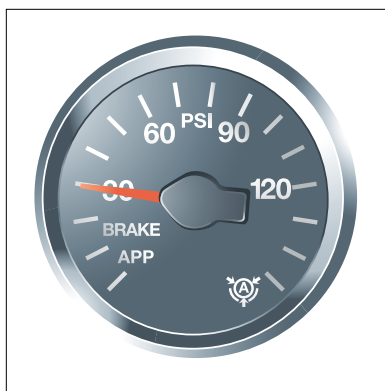

Some vehicles have air pressure gauges to indicate application pressure as well as pressure in the reservoirs.

There may be a single gauge or separate gauges for tractor and trailer brake application.

Tractors may have a single gauge that indicates application pressure if either the foot valve or trailer hand control valve is applied.

Anti-lock Braking Systems

Anti-lock Braking Systems (ABS) are typically made up of three main sections: speed sensing, decision-making, and brake releasing or modulation.

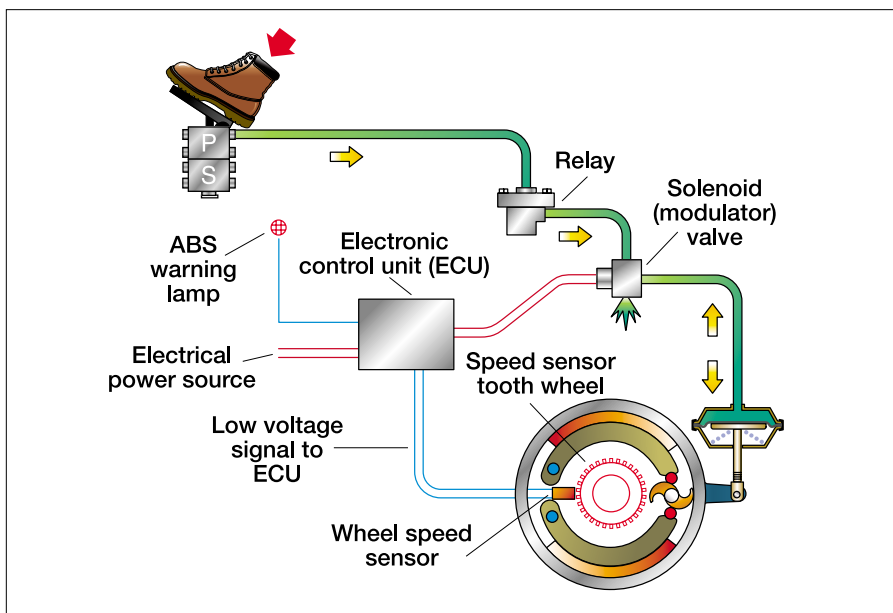

In this diagram, vehicle speed is sensed by magnetic pickups mounted in close proximity to toothed wheels that are attached to some or all of the wheel hubs. As the wheels rotate, a pulsating electrical current is generated.

This pulsating current is monitored by a simple computer called an **electronic control unit** (ECU). The ECU is powered by the vehicle electrical system. During normal brake application, if the ECU detects a sudden change in the pulsating current, the ABS system will activate.

If the brakes are applied too hard for road conditions, and a wheel lockup occurs, the rate of the pulsating current will rapidly decrease. The ECU, sensing the sudden drop in wheel speed, will signal electrically controlled solenoid air valves to release air pressure from the brake chambers at the affected wheels. The solenoid valves are frequently called **modulators**.

As the brakes begin to release, the wheels will regain traction, the pulsating current will be restored, and the ECU will allow the brakes to re-apply. If the lockup re-occurs, the apply-and-release cycle will repeat as often as necessary. Most systems are capable of cycling the brakes up to five times per second.

To achieve the shortest possible stopping distance on extremely slippery surfaces, you simply have to apply and maintain a heavy brake application. You need to apply the brake pedal in order to allow the ABS system work to stop the vehicle from skidding. The ABS system will rapidly apply and release the brakes as often as necessary. There may be some noise and vibration. ABS prevents the axle brakes from locking up allowing the driver to retain complete steering control.

The ABS lights for the tractor and trailer brakes should be on when you first start the tractor.



Trucks and tractors are equipped with a dash mounted failure warning lamp that monitors the ABS system. When the ignition switch is first turned on, the ABS system performs a self-checking sequence. Depending on the system, the dash lamp may light, flash briefly, then stay lit until vehicle speed reaches 7–11 km/h, or light briefly, then turn off.

If the lamp does not go out, or comes on during vehicle operation, it is signalling that there has been a failure in the ABS system. Normal braking is still operational, only the anti-lock feature is disabled. The vehicle may be driven to a service depot for repairs.

Trailer ABS air brake systems

Trailer ABS systems use similar components as those on trucks and tractors. The ECU may be powered from the stop lamp circuit, or may have a dedicated power source through the electrical connector.

Trailers with ABS air brakes will also have an indicator visible in the tractor's mirror to indicate if the system is not functioning properly. This warning light may be mounted on the front left side of the trailer or on the rear left side of the trailer.

On some air brake systems, there may be a trailer ABS warning indicator on the dashboard of the tractor.

This ABS warning light is positioned on the side of the trailer at the rear. The driver should be able to see it in the tractor side mirror.

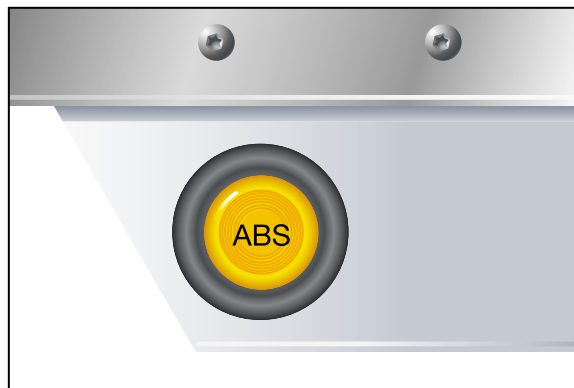



Review Questions

1. Why are air brakes, rather than hydraulic brakes, used on heavy commercial vehicles?
2. What are the five components of a simple air brake system?
3. What prevents total loss of air pressure in the service brake system in the event of an air line rupture between the compressor and the supply reservoir?
4. How can you tell how much air pressure is in the main reservoirs?
5. What must you do if the low pressure warning indicator activates?
6. What is one advantage of a dual air brake system?
7. In a dual air brake system, if an air line in the secondary braking system ruptures, how would you know? What would happen if you then made a brake application?
8. How does a spring parking brake work?
9. What are the two ways that the spring in a spring parking brake chamber can be held in the released position?
10. Why should you avoid compounding the brakes?
11. Why are spring parking brakes a reliable type of parking brake?
12. What is the purpose of the tractor protection system on a tractor?
13. If a driver makes a 20-pound (138 kPa) brake application with the hand valve, what is the application pressure at the tractor brakes?
14. What would happen if the control line to the trailer becomes disconnected while you are driving the tractor-trailer combination?
15. How does a wedge brake work?
16. How does an air-over-hydraulic braking system work?
17. Where would an air dryer be installed in an air brake system?
18. If you make a full brake application during an emergency stop with an automatic front wheel limiting system, how much air pressure is directed to the front brakes?